



**INSTALLATION INSTRUCTIONS  
FOR  
8430\*63(1,2)1 CHILLGRILLE™  
WITH MOUNTING KIT**

**8330-752 CONTROL BOX KIT (12 VDC COOL ONLY)  
9330C755 CONTROL BOX KIT (12 VDC HEAT READY)  
8530-750 CONTROL BOX KIT (24 VAC COOL ONLY)  
9530A751 CONTROL BOX KIT (12 VDC HEAT PUMP)**

**9430A751 ZONE CONTROL KIT (12 VDC COOL ONLY)  
9430A755 ZONE CONTROL KIT (12 VDC HEAT READY)  
9630A751 ZONE CONTROL KIT (12 VDC HEAT PUMP)**

**DESIGNED AND MANUFACTURED BY THE MAKERS OF  
COLEMAN®-MACH® AIR CONDITIONERS**



Coleman is a registered trademark of The Coleman Company, Inc. used under license. Mach is a registered trademark.

# TABLE OF CONTENTS

1.	Warnings .....	2
2.	Package Contents .....	2
3.	General Information .....	3
4.	Ceiling Plenum Installation Requirement .....	3
5.	Control Box Kits .....	4
6.	Control Box Kits (Zone) .....	5
7.	Wall Thermostats .....	5
8.	Supply Ducting and Registers .....	5
9.	Routing Thermostat Wiring .....	6
10.	Routing Thermostat Wiring (Zone) .....	6
11.	Routing 115 VAC Wiring .....	7
12.	Ceiling Plenum Mounting .....	8
13.	Installing the Control Box .....	8
14.	Installing the Control Box (Zone) .....	9
15.	Installing the Heater Assembly .....	11
16.	Install Air Grille Assembly .....	12

## 1. WARNINGS

### IMPORTANT NOTICE

These instructions are for the use of qualified individuals specially trained and experienced in installation of this type equipment and related system components.

Installation and service personnel are required by some states to be licensed. PERSONS NOT QUALIFIED SHALL NOT SERVICE THIS EQUIPMENT.

### WARNING

Improper installation may damage equipment, can create a hazard and will void the warranty.

The use of components not tested in combination with these units will void the warranty, may make the equipment in violation of state codes, may create a hazard and may ruin the equipment.

### WARNING – SHOCK HAZARD

To prevent the possibility of severe personal injury or equipment damage due to electrical shock, always be sure the electrical power to the appliance is disconnected during installation.

**CAREFULLY FOLLOW ALL INSTRUCTIONS AND WARNINGS IN THIS BOOKLET TO AVOID DAMAGE TO THE EQUIPMENT, PERSONAL INJURY OR FIRE.**

### NOTE

**The words “Shall” or “Must” indicate a requirement which is essential to satisfactory and safe product performance.**

**The words “Should” or May” indicate a recommendation which is not essential and not required, but which may be useful or helpful.**

## 2. PACKAGE CONTENTS

- 1) Duct Divider Board
- 1) Mount Frame
- 1) Chillgrille Assembly Consisting of:
  - 1) Chute/Supply Air Plate
  - 1) Shroud Assembly
  - 2) Filters
  - 2) Grilles

- 1) Small Parts Package Consisting Of:
  - 4) Bolts
  - 8) Screws – 3/8” Length

### 3. GENERAL INFORMATION

The flush mount ceiling plenum is designed for application in systems that utilize field fabricated (OEM supplied) cold air ducting. The ducting must be routed through the ceiling cavity (between the interior ceiling and roof). Ducting specifications are given in the section labeled "Supply Ducting and Registers".

This system utilizes a single, non-ducted centrally located return air opening. The return air opening is contained within the ceiling plenum. The ceiling plenum must be located directly below the roof opening used for mounting the roof top unit.

All manual controls have been removed from the ceiling plenum. They have been replaced with control relays. The relays are mounted in the electrical box of the ceiling plenum. The relays contain 12 VDC coils (which may be energized by a wall mounted thermostat), with contacts that control the 115 VAC used to power the roof top unit.

A low voltage controller controls all air conditioning functions. The low voltage controller controls a 12 VDC electrical circuit, which is used to energize the relays in the ceiling plenum. The low voltage controller that Airxcel, Inc. provides for the system may be a combination (Heat/Cool).

These low voltage controllers are capable of operating both the roof top air conditioner and any furnace with a 12 VDC control circuit of 1 amp or less (continuous current).

All air conditioning equipment is subject to freeze up when evaporator air flow is sufficiently reduced. Ducting of any length creates potential for reduced evaporator air flow and system freeze up. To protect both the installer and Airxcel, Inc. from conditions that promote reduced air flow and system freeze up, Airxcel, Inc. has equipped the ceiling plenum compressor control circuit with a low temperature probe. The low temperature probe monitors the temperature of the air conditioner evaporator coil. When the temperature of the evaporator coil drops below 28 degrees F, the switch will open, stopping compressor operation. Compressor operation will resume once the evaporator warms to 55 degrees F.

#### IMPORTANT

**The low temperature sensor is part of the ceiling plenum electrical circuit. The probe must be inserted into the evaporator coil of the roof top unit by the installer when bolting the ceiling plenum to the roof top unit.**

### 4. CEILING PLENUM INSTALLATION REQUIREMENT

1. The ceiling plenum must be installed under the roof opening.  
  
The ceiling plenum bolts below the roof top unit. Compression of the framed ceiling cavity between the roof top unit and the ceiling plenum is what holds both components in place.
2. Ceiling cavity depth (the measurement from the ceiling to the roof – maximum 6").
3. Provided with the ceiling plenum is a divider board which is used to separate the conditioned air from the return air supply.
4. The 115 VAC service for the roof top unit must be routed into the ceiling plenum. To prevent wire pinching and to promote ease of installation, allowances must be made for routing the 115 VAC supply wiring into the front of the roof opening.
5. The wirebox has a 9 pin receptacle extending from the front. This mates with the roof unit 115 volt electrical conduit. When making this connection, verify that the plugs are properly aligned and have snapped together securely.
6. The wirebox for the heat/cool units will have a two pin receptacle which mates with the umbilical plug from the heater assembly.
7. **LOW VOLTAGE CONTROL WIRING (WALL THERMOSTAT)**
  - A. A low voltage terminal strip on the front of the box connects to the low voltage control wires. The wires attach by 1/4" quick connects.
  - B. The low voltage control wiring must be run from the wall thermostat mounting location to the wirebox low voltage terminals. To prevent wire pinching and to promote ease of installation, allowances must be made for routing the low voltage wiring into the front of the opening.

## Standard Control Box

Cool Only Boxes	Plenum Terminal Designation	Thermostat Wire Connection	Function of Low Voltage Terminal Extending From Ceiling Plenum	Heat/Ready Boxes
Yes	B	BLUE	Completes -12 VDC circuit for all relays	Yes
Yes	Y	YELLOW	Energizes coil on Compressor Relay	Yes
Yes	GH	GREEN	Energizes coil on High Fan Relay	Yes
Yes	GL	GRAY	Energizes coil on Low Fan Relay	Yes
Yes	FREEZE		Evaporator Freeze Sensor Connections	Yes
Yes	FREEZE			
No	W	WHITE	Energizes coil on Heat Relay	Yes

## Zone Control Box

Plenum Terminal Designation	Thermostat Wire Connection	Function of Low Voltage Terminal Extending From Ceiling Plenum
R+	Red	Provides +12 VDC to upper unit control box
Cool Shed (2 Terminals)		Removing jumper wire will allow system to be connected to N.C. contacts of a load shed system
Heat Shed (2 Terminals)		Removing jumper wire will allow system to be connected to N.C. contacts of a load shed system
Room (2 Terminals)		The remote room temperature sensor attaches here*
Freeze (2 Terminals)		Freeze sensor attaches here
Gen		Allows system to connect to an automatic start generator system
B-	Blue	Provides -12 VDC to upper unit control box
Sig 1	Purple	Communication line between upper unit control box and thermostat
Sig 2	Black	Communication line between upper unit control box and thermostat

\* Zone 1 has option of using thermostat as room sensor

## 5. CONTROL BOX KITS

### 1. 8330-752 – 12 VDC Controlled, Cool Only

This kit consists of a control box assembly. The evaporator freeze sensor is shipped in an envelope for installation by quick connects to terminal strip “Freeze”.

### 2. 9330C755 – 12 VDC Controlled, Heat Ready

This kit consists of a control box assembly. The evaporator freeze sensor is shipped in an envelope for installation by quick connects to terminal strip “Freeze”. The heater assembly for the 47000 series units is 47233\*4551. The heater assembly for the 48000 and 49000 series units is 9233\*4551. They are purchased separately.

### 3. 8530-750 – 24 VAC Controlled, Cool Only

This kit is similar to the 8330-752 with the exception of a transformer that is attached to the box assembly.

### 4. 9530A751 – 12 VDC Controlled, Heat Pump

This kit is similar to the 9330C755 but is wired for the heat pump function.

## 6. CONTROL BOX KITS (ZONE)

### 1. 9430A751 – 12 VDC Zone Controlled, Cool Only

This kit consists of a control box assembly. The evaporator freeze sensor is shipped in an envelope for installation by quick connects to terminal strip marked “FREEZE”.

### 2. 9430A755 – 12 VDC Controlled, Heat Ready

This kit consists of a control box assembly. The evaporator freeze sensor is shipped in an envelope for installation by quick connects to terminal strip marked “FREEZE”. The heater assembly for the 47000 series units is 47233\*4551. The heater assembly for the 48000 and 49000 series units is 9233\*4551. They are purchased separately.

### 3. 9630A751 – 12 VDC Zone Controlled, Heat Pump

This kit consists of a control box assembly. The evaporator freeze sensor is shipped in an envelope for installation by quick connects to terminal strip marked “FREEZE”. Backup electric heat is available as an optional kit. The heater assembly for the 47000 series units is 47233\*4551. The heater assembly for the 48000 and 49000 series units is 9233\*4551. They are purchased separately.

## 7. WALL THERMOSTATS

1. Locate and install the thermostat per instructions found with the thermostat.
2. For 12 VDC thermostats, it is required that the thermostat 12 volt negative connection be routed directly from the converter or battery. It is highly desirable to provide 12 volt control power from the battery side of the converter. These precautions should prevent control problems.

3. For the 24 VAC thermostat, keep in mind that if the application will involve operation while in motion or subject to vibration, an electromechanical thermostat must not be used as electromechanical contacts will “chatter” the compressor relay if used in high vibration applications. For applications subject to vibration, an electronic wall thermostat must be used. Airxcel, Inc. part numbers are 8330B3241 or 7330B3441.

## 8. SUPPLY DUCTING AND REGISTERS

### A. Ducting

1. The field fabricated supply ducting must open into both ends of the ceiling plenum. Two ducts are required; one duct attached to the front, and one to the rear of the plenum (See Figure 1).
2. Each duct must have a minimum height of 1 1/2”, maximum height cannot exceed 4 inches. Total free area inside each duct must be no less than 10 square inches.

#### NOTE

To decrease restriction and increase air flow, the ducting should make as few bends and turns as possible. When corners or turns are required, we recommend that you radius the corners to keep air flow at a maximum.

Ten (10) square inches of free area per duct is the minimum requirement, larger ducting will improve air flow and system performance.

3. Where ducting secures to the ceiling plenum, maximum width is 7 inches.
4. All field fabricated cold air supply ducting must be insulated and must have a vapor barrier.

#### IMPORTANT

**Insulation reduces cooling loss and helps prevent water staining of the vehicle ceiling due to moisture condensation.**

### B. Registers

Supply (cold air) registers should have a minimum discharge area of 48 square inches per system, or 24 square inches per duct. A minimum of 6 is recommended.

## 9. ROUTING THERMOSTAT WIRING

1. Following the instructions packed with the thermostat, determine a location for thermostat mounting.
2. Following Airxcel, Inc. low voltage wiring specifications and all local and national electrical codes:
  - A. Route the thermostat 12 VDC supply wiring from the power source to the thermostat mounting location.

Two wires are required:  
One supply lead must be +12 VDC and red in color.  
The second supply lead must be -12 VDC and blue in color.
  - B. To protect the wall mount thermostat from over-current damage, a 2 amp fuse has been provided with the thermostat.
  - C. Route the thermostat control wiring from the thermostat mounting location into the front of the ceiling plenum opening.

Four (4) wires are required (5 wires for heat/cool boxes). These wires are as follows:

    - (1) Blue wire for -12 VDC circuit
    - (1) Yellow wire for compressor circuit
    - (1) Green wire for high fan circuit
    - (1) Gray wire for low fan circuit
    - (1) White wire for heat circuit
3. Airxcel, Inc. low voltage wiring specifications:
  - A. All low voltage wiring should be 18 gauge minimum.
  - B. Low voltage wiring must be routed into the front side of the ceiling plenum opening.

## 10. ROUTING THERMOSTAT WIRING (ZONE)

1. Following the instructions packed with the thermostat, determine a location for thermostat mounting.
2. Following Airxcel, Inc. low voltage wiring specifications and all local and national electrical codes:
  - A. Route the thermostat control wiring from the thermostat mounting location into the front of the ceiling plenum opening.

These wires are as follows:

    - (1) Red wire to +12 VDC circuit (R+)
    - (1) Blue wire to -12 VDC circuit (B-)
    - (1) Purple wire to communication signal (Sig 1)
    - (1) Black wire to communication signal (Sig 2)
    - (1) Any color for auto generator start (optional) (Gen)
    - (2) Any color for room temperature sensor (zone 1 optional, required for other zones)
    - (1) For each heating appliance (Up to 4)
    - (2) Any color for cool load shed (optional)
    - (2) Any color for heat load shed (optional)
  - B. See Figure 5 for wiring requirements for multiple zones.
3. Airxcel, Inc. low voltage wiring specifications:
  - A. All low voltage wiring should be no smaller than 18 gauge.
  - B. Low voltage wiring must be routed into the front side of the ceiling plenum opening.
  - C. Low voltage wiring should not be routed with high voltage wiring.
  - D. If low voltage and high voltage wires must cross, they should do so at right angles from one another.

# 11. ROUTING 115 VAC WIRING

Following Airxcel, Inc. high voltage wiring specifications and all local and national electrical codes, route the roof top unit 115 VAC supply wiring from its power source to the wirebox.

For lengths greater than 50', use #10 AWG or larger copper conductors. Match to the overcurrent protection device provided.

## High Voltage Wiring Specifications based on Minimum Overcurrent Protection Device Amperage – (see upper unit nameplate)

Circuit Protection – Refer to upper unit nameplate.

## High Voltage Wiring Specifications based on Overcurrent Protection Device rated higher than the minimum required (see upper unit nameplate)

**Follow all local and NEC (National Electrical Code) for proper sizing of wire AWG based on Overcurrent Protection Device selected and the length of the wiring run to the air conditioner.**

1. U.L. requires copper conductors only with minimum #12 AWG when using the minimum recommended overcurrent protection device. Higher rated devices or longer wiring runs will require #10 AWG or greater copper conductors.
2. To prevent voltage drops greater than 10% during starting loads, adhere to the following guideline:

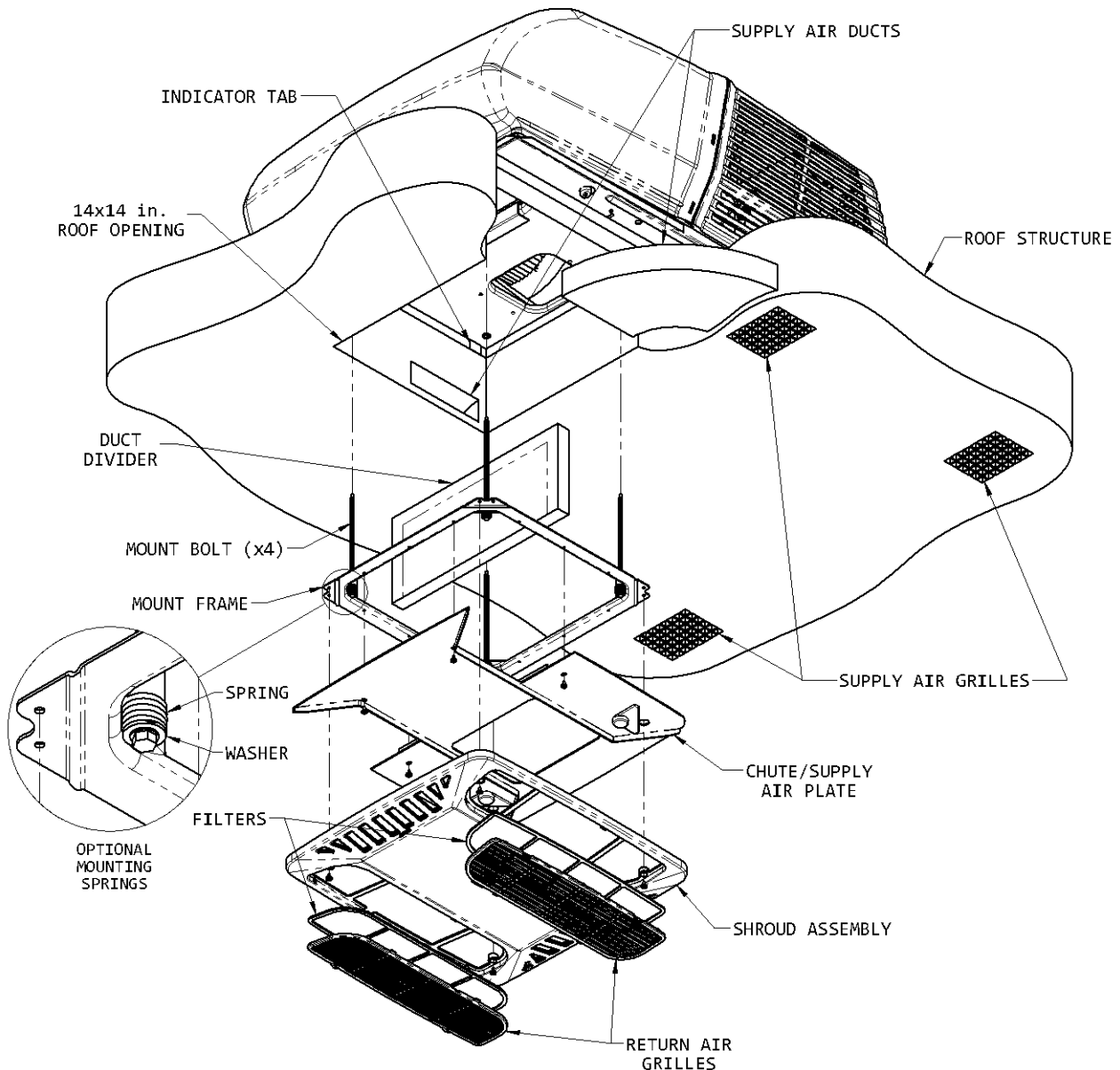


FIGURE 1

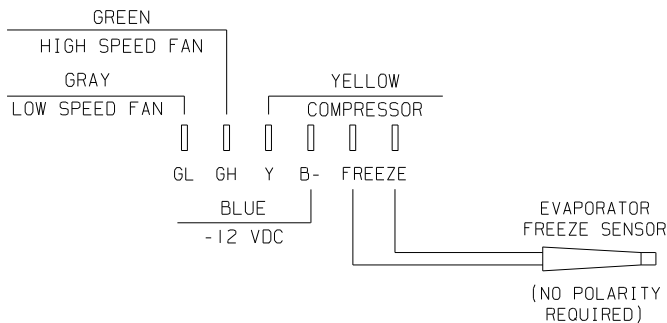
## 12. CEILING PLENUM MOUNTING

1. Place the air conditioner over the roof opening.
2. Position the mount frame into the ceiling opening (See Figure 1).
3. Using the four bolts provided, secure the mount frame to the roof top unit. The four mounting bolts are to be applied up through the bottom of the mount frame and into the bottom of the roof top unit (See Figure 1). Tighten each bolt until the indicators of the gasket are at roof level.
4. Route the conduit into the return opening.
5. Measure the distance between the ceiling and the upper unit basepan, add 1/2" to this measurement and cut the duct divider to this height if necessary. **ALWAYS CUT OFF THE BOTTOM EDGE (THE EDGE WITHOUT FOAM STRIP).**
6. Carefully wedge this divider between the walls of the roof opening and up against the upper unit basepan with the silver side facing forward.

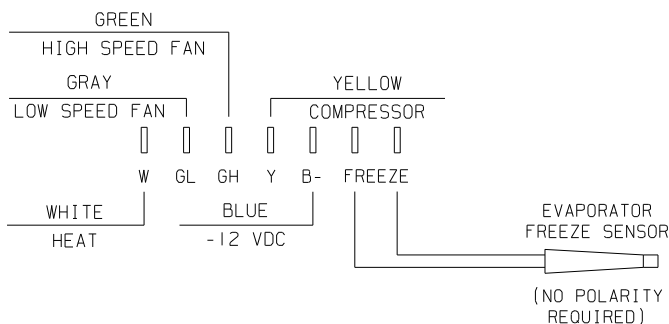
## 13. INSTALLING THE CONTROL BOX

1. Remove the control box assembly cover which may be held by two sheet metal screws. Feed the field lead wires and ground through the strain relief found with the control box.
2. Attach black supply conductor to black "pigtail" lead, white to white and ground to green with wire nuts provided in control box kit.
3. Insure that no bare wires can come into contact with live electrical parts and that wires cannot be pinched between the control box sides and lid. Insert the strain relief into the control box entry hole to secure the field wiring. Reinstall the control box lid.
4. Attach the thermostat wires to the control box per illustrations below:

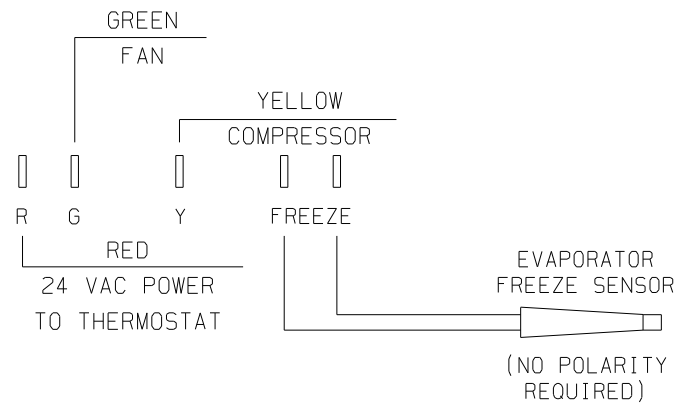
### A. Control Box 8330-752



### B. Control Box 9330C755, 9530A751



### C. Control Box 8530-750



5. Connect the roof unit 115 volt electrical conduit to the wirebox 9 pin receptacle and verify that the plugs are properly aligned and have snapped together securely.
6. Locate the two machine screws inside the evaporator cover of the upper unit. Align the control box over the screws and use the wing nuts supplied with the control box to secure it to the upper unit enclosure. For the 47000 series units, see Figure 8.
7. Insert the evaporator freeze sensor between evaporator fins near the bottom center of the evaporator and between the bottom two tubes (See Figure 2). Insert straight in until contacting the staggered tube directly in back of the insertion point. When contact has been made, elevate the exposed end of the sensor approximately 45 degrees, then continue insertion at a 45 degree angle until the sensor is completely embedded into the evaporator.



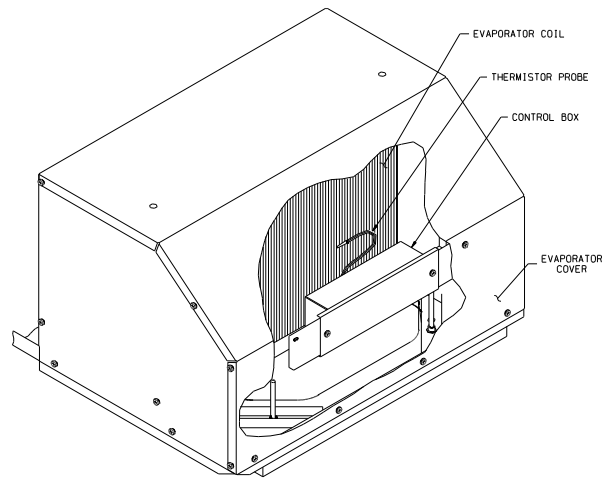


FIGURE 2

## 14. INSTALLING THE CONTROL BOX (ZONE)

1. Remove the control box assembly's cover which is held by two sheet metal screws.
2. Set the "zone" jumper to the proper zone position for the particular position the air conditioner or heat pump will be in the coach (**Refer to Figure 3 – Zone 1 is shown**). Zones should be numbered from the front to the back of the coach with Zone 1 in front.
3. Set the "HP"/"NON HP" jumper to "HP" if the unit is a heat pump or to "NON HP" if the unit is not a heat pump (**Refer to Figure 3 – Non HP is shown**).
4. Feed the field lead wires and ground through the strain relief found with the control box then through the 7/8" hole in the side of the box.
5. Wire nut the black field power conductor to the stripped black 12-gauge wire in the control box.
6. Wire nut the white field power conductor to the stripped white 12-gauge wire in the control box.
7. Wire nut the ground field power conductor to the stripped green ground wire in the control box.
8. Insure that no bare wires can come into contact with live electrical parts and that wire cannot be pinched between the control box sides and lid. Insert the strain relief into the control box entry hole to secure the field wiring. Reinstall the control box lid.
9. Attach the thermostat wires to Zone 1 control box per the illustration below (Refer to Figure 4):

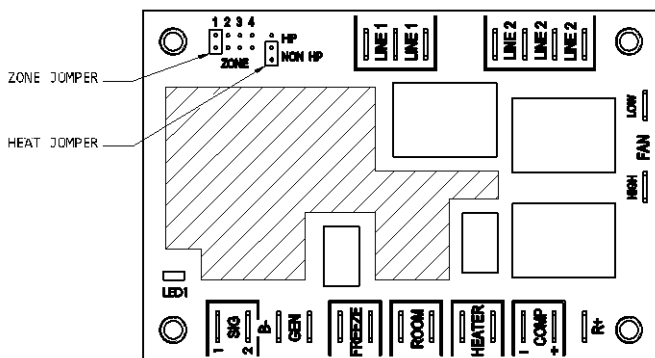


FIGURE 3

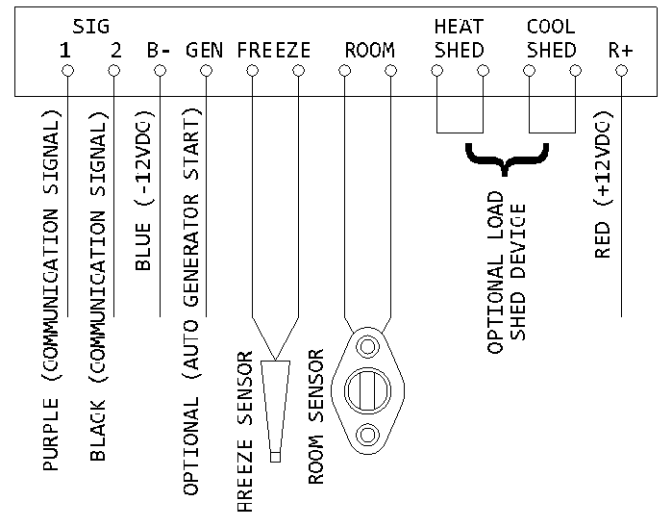
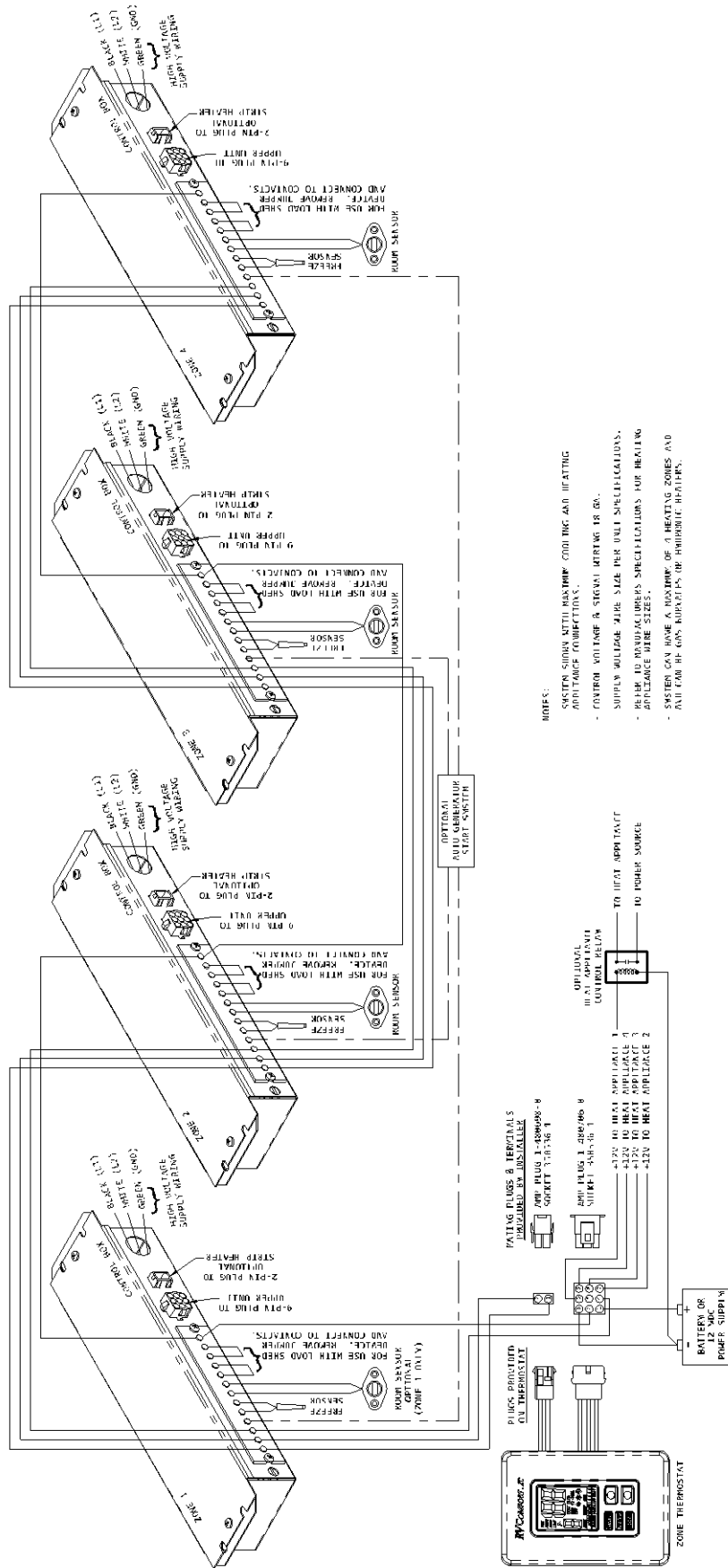


FIGURE 4

5. Wire nut the black field power conductor to the stripped black 12-gauge wire in the control box.



- NOTES:**
- SYSTEM SHOWN WITH MAXIMUM COOLING AND HEATING CAPACITY CONNECTIONS.
  - CONTROL VOLTAGE & SIGNAL WIRING IS DC.
  - SUPPLY WIREGAUGE WIRE SIZE PER UNIT SPECIFICATIONS.
  - WIRE TO HEAT APPLIANCES SPECIFICATIONS FOR HEATING APPLIANCE WIRE SIZES.
  - SYSTEM CAN HAVE A MAXIMUM OF 4 HEATING ZONES AND AN UNLIMITED NUMBER OF AIRBORNE HEATERS.

FIGURE 5

Zone 2 is wired in by jumpering from Sig 1, Sig 2, B- and R+ on Zone 1 box to Zone 2 box. Zone 3 is wired in by jumpering from Sig 1, Sig 2, B- and R+ on Zone 2 box to Zone 3 box. Zone 4 is wired in by jumpering from Sig 1, Sig 2, B- and R+ on Zone 3 box to Zone 4 box (See Figure 5).

10. Connect the roof unit 115 volt electrical conduit to the wirebox 9 pin receptacle and verify that the plugs are properly aligned and have snapped together securely.
11. Position the control box over the screws and use the wing nuts to fasten the control box to the upper unit enclosure. For the 47000 series units, see Figure 8.
12. Insert the evaporator freeze sensor between evaporator fins near the bottom center of the evaporator and between the bottom two tubes (See Figure 2). Insert straight in until contacting the staggered tube directly in back of the insertion point. When contact has been made, elevate the exposed end of the sensor approximately 45 degrees, then

continue insertion at a 45 degree angle until the sensor is completely embedded into the evaporator.

13. Complying with the warnings listed below, connect the 115 VAC supply wiring to its power source. Be sure all power remains off until beginning checkout procedure.

**DANGER**

**TO PREVENT THE POSSIBILITY OF SHOCK INJURY FROM APPLIANCE OPERATION:**

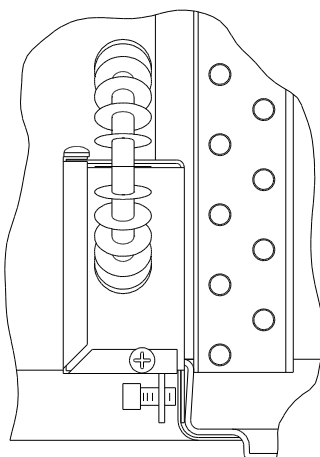
**THE WHITE WIRE MUST BE CONNECTED TO NEUTRAL IN THE SERVICE BOX ENTRANCE AND THE MECHANICAL GROUND MUST BE CONNECTED TO A GROUNDING LUG IN THE SERVICE BOX OR THE MOTOR GENERATOR COMPARTMENT.**

**15. INSTALLING THE HEATER ASSEMBLY**

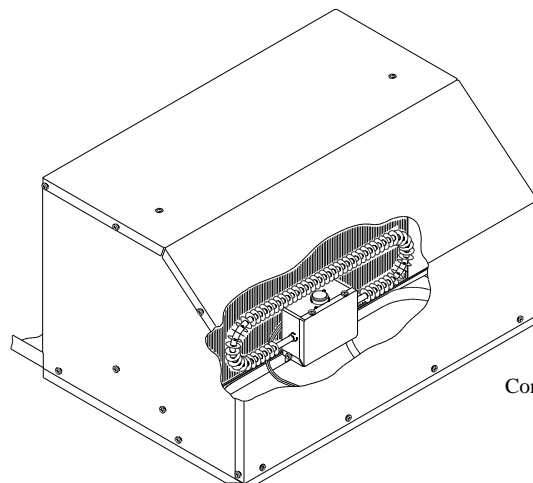
1. If adding the electric heater, the assembly can now be installed.
2. For installation on 48000 and 49000 series units, position the heater assembly into the return air opening as shown in Figure 7. Insure that the set screw is retracted sufficiently to allow installation over the basepan extrusion. The heater bracket **must be installed between the basepan and the plastic drain pan** (See Figure 6). Tighten set screw to secure the assembly so as to prevent movement. 47000 series units will mount as shown in Figure 9 using wing nuts.

3. Insert the two-pin connector of the heater umbilical into the receptacle on the control box. Insure that the connector snap-locks into position.

**TIE ALL WIRING TO INSURE NO CONTACT WITH THE HEATER OR ANY SHARP EDGES. KEEP IN MIND THAT HIGH VELOCITY AIR WILL BE ENCOUNTERED IN THIS AREA.**

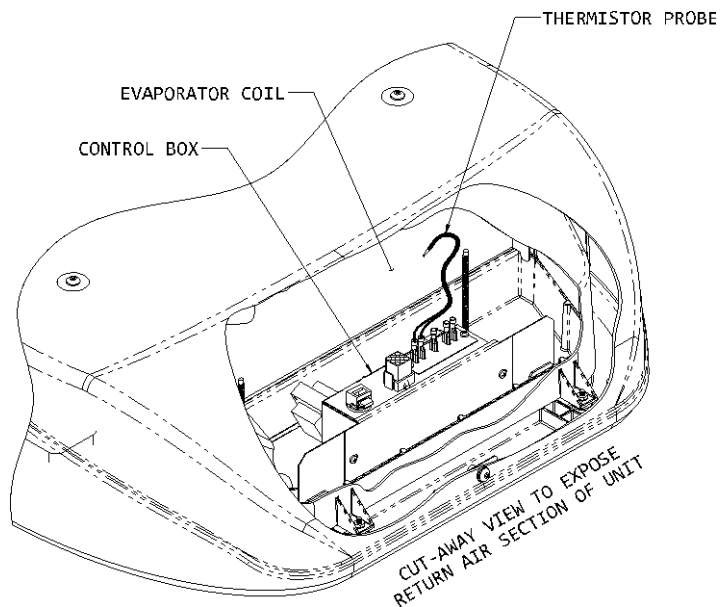


**FIGURE 6**

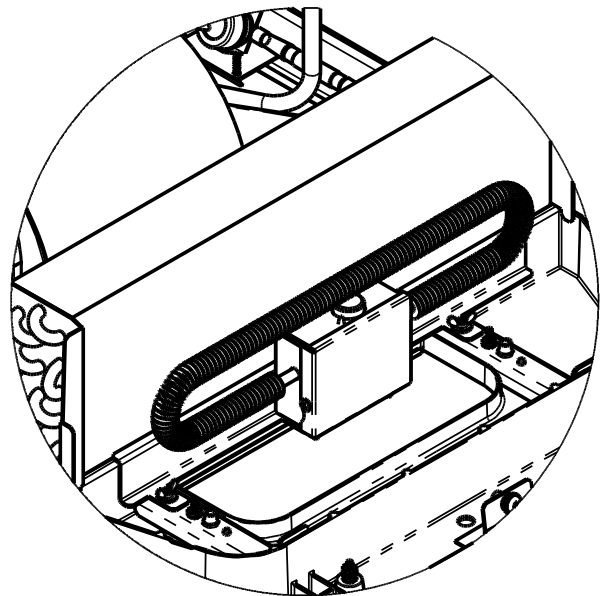


Control Box Not Shown For Clarity

**FIGURE 7**



**FIGURE 8**



**FIGURE 9**

## 16. INSTALL AIR GRILLE ASSEMBLY

1. Raise the chute/supply air plate to the mount frame and ensure the plenum duct divider is positioned between the two ribs. Install the chute/supply air plate to the mount frame with 4 screws provided in the parts package (See Figure 1).
2. Temporarily remove the return air grilles and filters from the shroud assembly.
3. Raise the shroud assembly so that it properly nests with the chute/supply air plate and attach the shroud assembly to the mount frame with 4 provided screws.
4. Reinstall the filters and return air grilles in the shroud assembly.
5. Installation is now complete.

Airxcel, Inc.  
 RV Products Division  
 P.O. Box 4020  
 Wichita, KS 67204

Web: [www.rvcomfort.com](http://www.rvcomfort.com)  
 Support: [www.rvsupport@airxcel.com](mailto:www.rvsupport@airxcel.com)  
 Sales: [www.rvpsales@airxcel.com](mailto:www.rvpsales@airxcel.com)