



SERVICE MANUAL

FOR

471X3*79X5



Service Contact:
Coast RV Pty Ltd.
PO BOX 6287
SILVERWATER NSW 1811 Australia
Tel: +61-2-9645 7600
technical@coastrv.com.au

TABLE OF CONTENTS

I.	Warnings	2
II.	Individual Electrical Component Checkouts	2
III.	Service Problems and Possible Solutions	3
IV.	System Wiring Diagram	6

I. WARNINGS

IMPORTANT NOTICE

These instructions are for the use of qualified individuals specially trained and experienced in installation of this type equipment and related system components.

Installation and service personnel are required by some states to be licensed. PERSONS NOT QUALIFIED SHALL NOT SERVICE THIS EQUIPMENT.

II. INDIVIDUAL ELECTRICAL COMPONENT CHECKOUTS

WARNING

CAREFULLY FOLLOW ALL INSTRUCTIONS AND WARNINGS IN THIS BOOKLET TO AVOID DAMAGE TO THE EQUIPMENT, PERSONAL INJURY OR FIRE.

Overload Switch

The switch is connected in series with common so if the switch opens, it will cut the power to the compressor motor. The switch will open as a result of either or both of two conditions that could be harmful to the compressor.

a) High Amperes (Current)

The switch contains a heater which increases in temperature as the current increases. The higher temperature warps the switch and will cause it to open before the windings reach a dangerous temperature.

b) High Temperature (Thermal)

The switch is clamped tightly against the compressor housing and located close to the windings. Therefore, as the windings reach a higher temperature, it takes less current to cause the switch to open.

As can be seen, the switch is always affected by a combination of current to the compressor and winding temperature.

Run Capacitors

The purpose of the run capacitors is to improve motor efficiency during running. The run capacitors are always connected between the start and run or main terminals of the motor.

Indoor Thermistor

The thermistor is a freeze protection device installed in the compressor relay circuit to prevent evaporator coil freeze-ups. This device is a semi-conductor which has electrical resistance that varies with temperature. The thermistor cutout temperature is 26 degrees F. (± 3 degrees), -3 degrees C (± 1.7 degrees) and reset temperature is 40 degrees F. (± 3 degrees), 4.4 degrees C (± 1.7 degrees).

Outdoor Thermistor and Defrost Cycle

The outdoor thermistor is a freeze protection device installed in the compressor relay circuit to prevent outdoor coil freeze-ups. This device is a semi-conductor which has electrical resistance that varies with temperature. This device is used in conjunction with a defrost circuit allowing the unit to run at ambient temperatures below 3 degrees C.

During reverse cycle operation, as the outdoor coil sensor temperature drops below -4 degrees C, a defrost cycle is initiated. A single defrost cycle takes 60 minutes to complete. For 57 minutes the temperature of the outdoor coil sensor is monitored. (If at any point after the first 10 minutes of the cycle has passed the temperature rises above 2 degrees C, the cycle is terminated and normal reverse cycle operation resumes.)

After 57 minutes, the indoor blower is shut down and the reversing valve is un-energized shifting the unit back into A/C mode for 3 minutes. This will heat the outdoor coil and melt frost or ice that has formed on the coil. After 3 minutes, the reversing valve is re-energized, putting the unit back in reverse cycle operation. At this point a 15 second delay on blower start-up will occur to avoid any cold air being blown into the coach. The 60 minute cycle will restart unless the unit satisfies or the temperature of the outdoor coil has risen above 2 degrees C.

If at any time the temperature of the outdoor coil sensor drops below -17 degrees C, the unit will be shut down completely and an auxiliary heat source must be used. If this occurs, the

unit will resume operation only when the outdoor coil sensor temperature reaches 1 degree C or higher.

III. SERVICE PROBLEMS AND POSSIBLE SOLUTIONS

Problem: Unit does not start

<u>Likely Causes</u>	<u>Correction</u>
Main power supply	Check circuit breaker and ensure that there is power to the unit.
Power at unit	Unscrew and disconnect ceiling assembly (see installation manual). Check to ensure that there is power at the main power cable going into the unit.
Power at unit but still does not function	Power off the unit. Remove shroud from the unit. Remove the electrical box. Remove cover and check fuse. If broken, replace and re-power unit.
If fuse breaks again	Power off, then disconnect the 9 pin plug and replace fuse. Then power on, if the fuse breaks again, then there is a problem in the control board. Replace the main electric control box (See Figure 2).
If the fuse does not break	The fault is in either the indoor blower or compressor. Check to see which part is defective.
Compressor check Compressor windings	Main Winding – 2.9 Ohms @ 25C Start Windings – 4.1 Ohms @ 25C Replace if faulty.

Problem: Unit powers up but compressor does not start

<u>Likely Causes</u>	<u>Correction</u>
Run Capacitor	Check run capacitor inside of electrical box situated under condenser fan (See Figure 3). Replace if defective.
Compressor Overload	Check compressor overload switch on compressor. Replace if defective.
Freeze Switch	Check freeze switch to ensure that the contacts are closed.

**Problem: Low air flow from ceiling assembly
No air flow from ceiling assembly**

<u>Likely Causes</u>	<u>Correction</u>
Indoor Blower	Power off unit, remove shroud, inspect wiring and check that the amp draw (see data sticker for amp draw). Power off unit, remove shroud, inspect wiring and check that there is power arriving at the motor. Check capacitor and replace if defective. If capacitor is good, replace blower motor.

Problem: Poor performance in either cooling or heating mode

Likely Causes

Correction

Outdoor coil is partially blocked by debris such as leaves, etc.

Power off unit, remove shroud and clean outside coil.

Problem: No heating or cooling but fans and compressor are running

Likely Causes

Correction

Reversing solenoid

Power off unit, remove shroud and switch on power. Check that the solenoid is operating. Replace if defective. If reversing valve solenoid is functioning correctly, then replace reversing valve.

Problem: Unit not functioning and no LED light indication on ceiling assembly

Likely Causes

Correction

No power to unit

Check power supply to the unit.

Damaged or loose Communication cable

Unscrew and disconnect ceiling assembly (see installation manual). Check to ensure that the Communication cable is connected correctly and not damaged.

Board failure

First, replace electronic board in ceiling assembly. If unit still does not operate, replace main control box (See Figure 2).

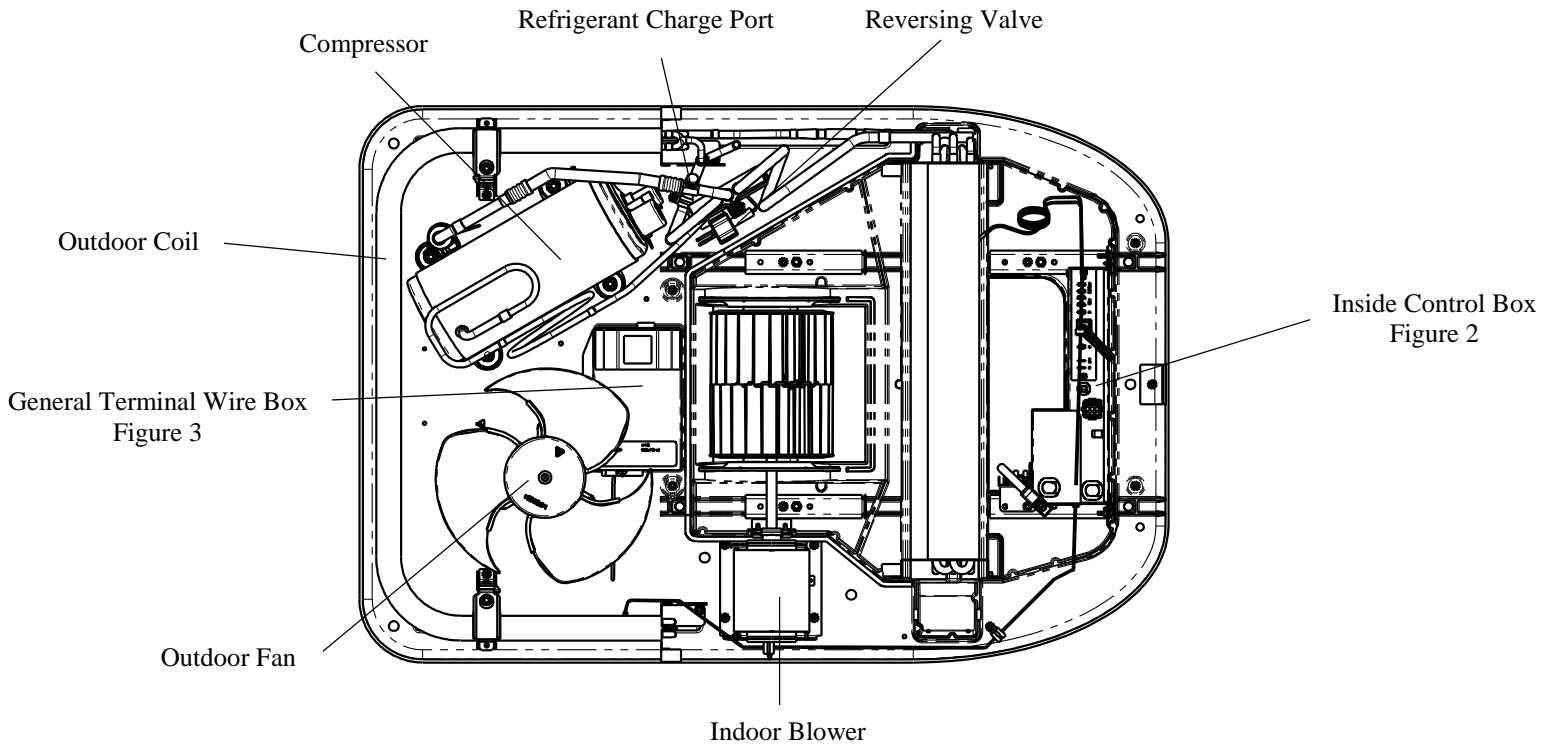

FIGURE 1

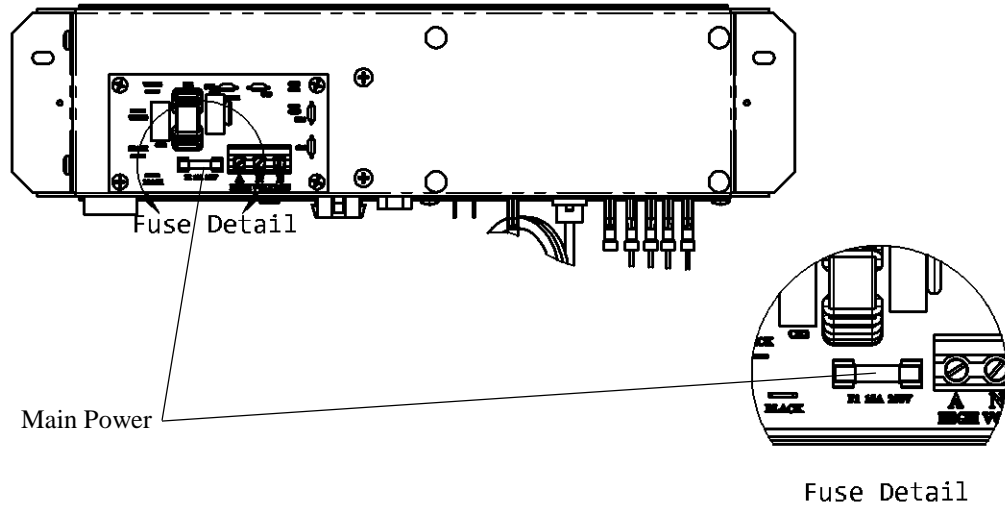

FIGURE 2

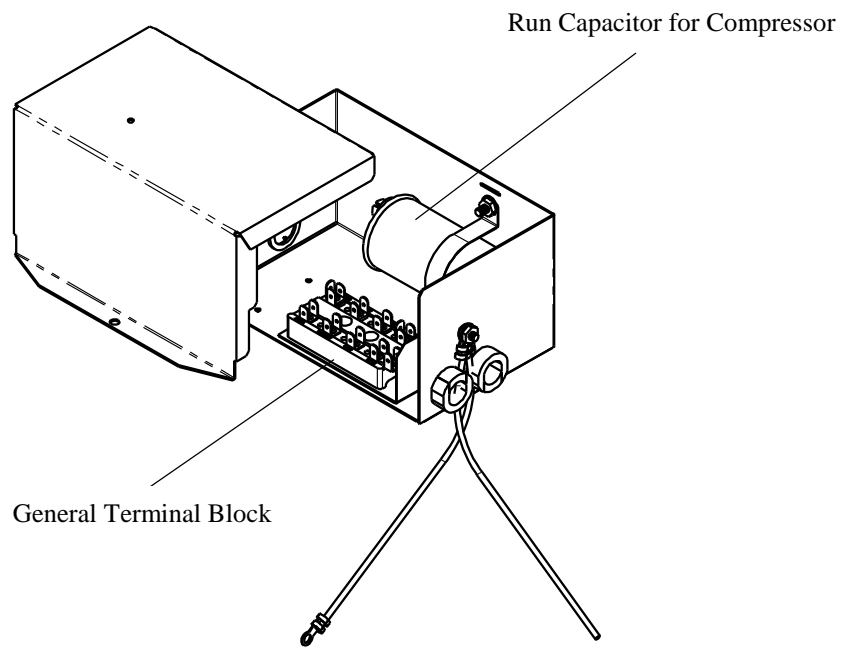
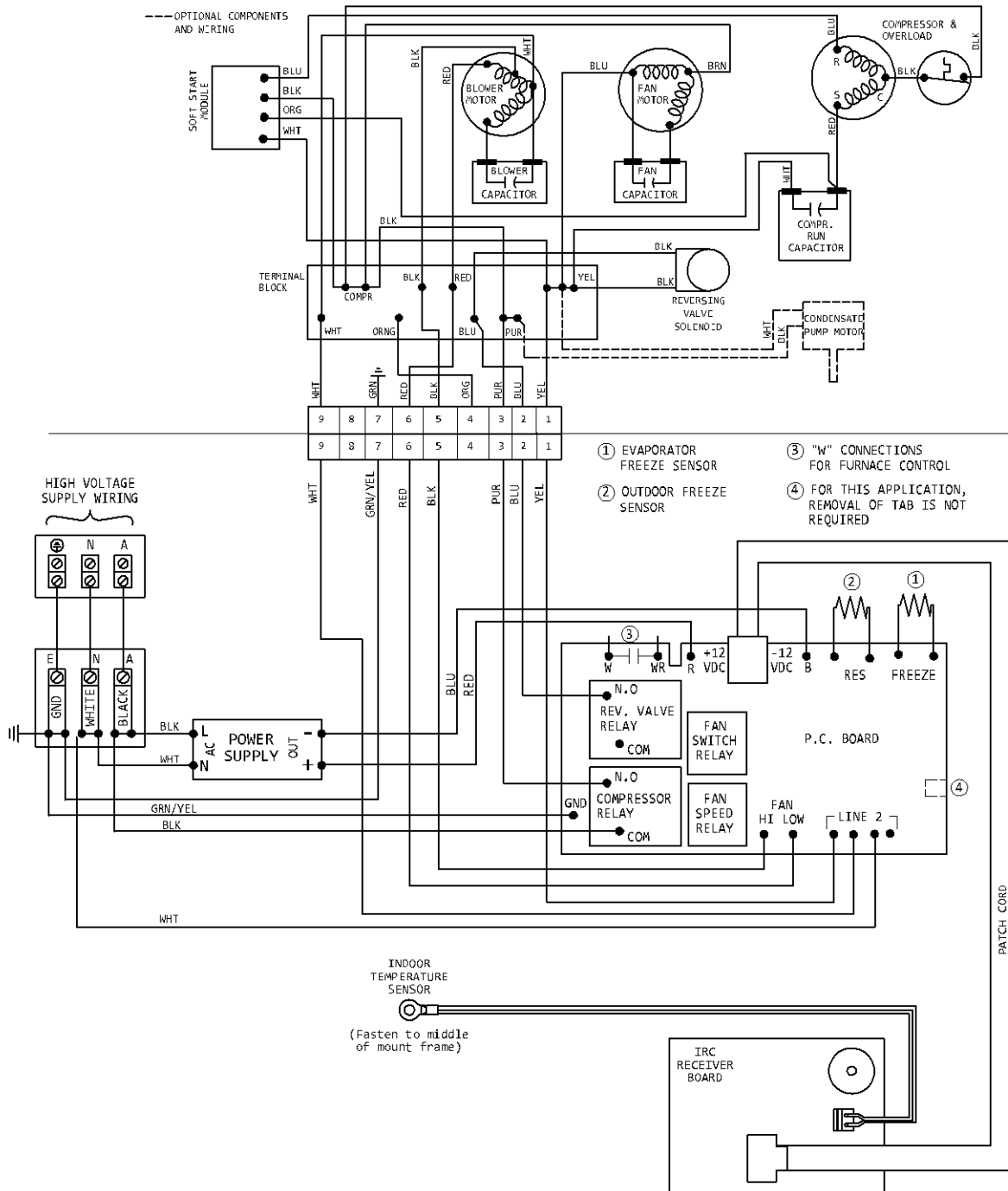

FIGURE 3

IV. SYSTEM WIRING DIAGRAM

SYSTEM WIRING DIAGRAM



Airxcel, Inc.
 RV Products Division
 P.O. Box 4020
 Wichita, KS 67204