

Installation Instructions

48203-1201

TSR Top-Down Mounting Kit

Important! When using this method of roof top unit installation, an electric heat element must not be installed. If an electric heater is to be installed, the standard interior frame mounting method must be used to allow access to the heater from below.

When using this top-down installation method, the vehicle must be structured with a minimum 0.200" thick 6061-T6 aluminum plate embedded in the vehicle roof for the roof top unit mounting screws to engage.

1. Remove roof top unit plastic shroud.
2. At each of the front corners of the roof top unit, remove the 2 screws along the side and 1 screw & clip in the lower-front as shown in Figure 1. Re-use these components to attach the 2 mounting brace assemblies. See Figure 1.
3. Insert a nylon sleeve into each of the mounting gaskets and apply them to the bottom of the mounting braces as shown in Figure 1.
4. Apply the 2 rubber pads to the bottom of the unit base pan on the depressed areas as shown in Figure 1.

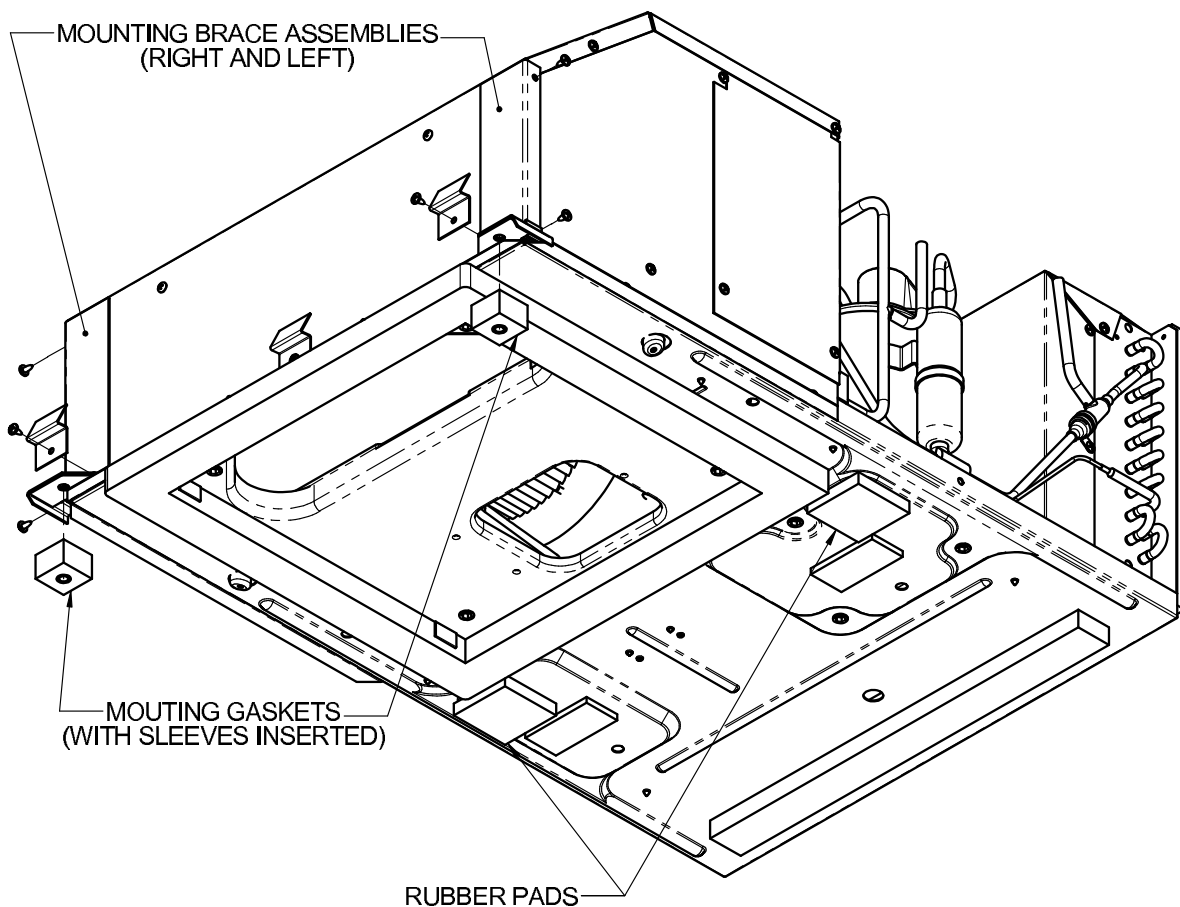

5. Remove the 2 sheet metal screws through the unit bulkhead flange as indicated in Figure 2.
6. Apply silicone to the bottom of the roof top unit 14 x 14 gasket and align over the opening in the vehicle roof for installation.
7. Using 2 self-drilling screws and gasketed washers, run the screws down through the mounting braces, through the spacers and into the vehicle roof. Tighten screws just until the spacers pull down to the roof. Thread the remaining screws with gasketed washers through the bulkhead flange holes and tighten until the unit gasket has been evenly compressed. Use care to NOT STRIP the screws. See Figure 2.
8. Apply silicone to the top of each mounting screw head and re-install the roof top unit plastic shroud.

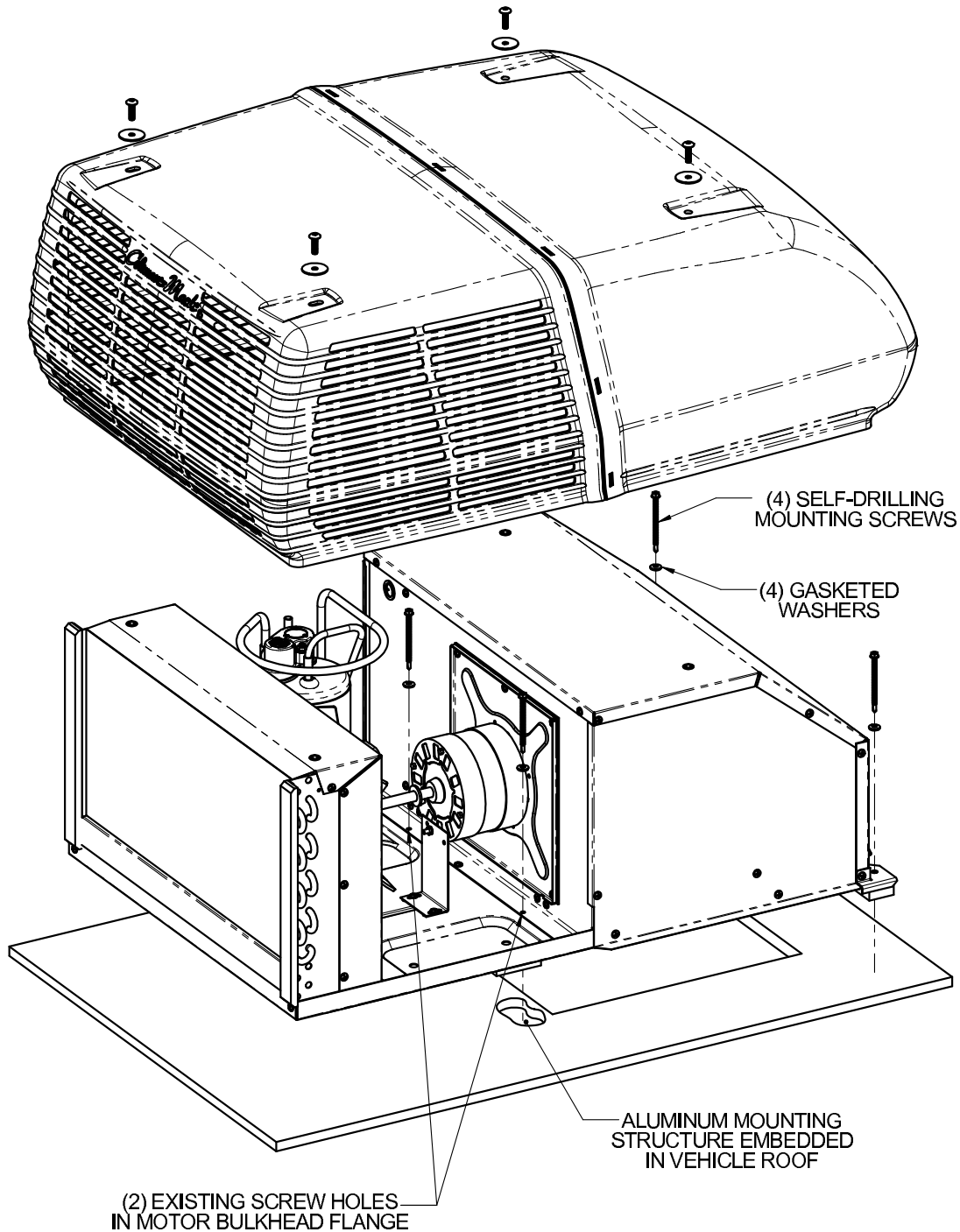

Figure 2