



INSTALLATION INSTRUCTIONS

FOR

6538 SERIES

TWO TON HIGH EFFICIENCY

PACKAGED AIR CONDITIONER

TABLE OF CONTENTS

1.	Warnings	2
2.	Component Match-Up	3
3.	Unit Depiction Figures	3
4.	General Information	4
5.	Unit Installation	4
6.	Duct Mounting and Configuration	5
7.	Duct and Register Specifications	5
8.	115 VAC Electrical Wiring	7
9.	Thermostat and 12 VDC Wiring	8
10.	Checkout	10

1. WARNINGS

IMPORTANT NOTICE

These instructions are for the use of qualified individuals specially trained and experienced in installation of this type equipment and related system components.

Installation and service personnel are required by some states to be licensed. PERSONS NOT QUALIFIED SHALL NOT INSTALL NOR SERVICE THIS EQUIPMENT.

NOTE

The words "Shall" or "Must" indicate a requirement which is essential to satisfactory and safe product performance.

The words "Should" or "May" indicate a recommendation or advice which is not essential and not required but which may be useful or helpful.

WARNING

DO NOT PERFORM A DIELECTRIC STRENGTH TEST (HYPOT) ON 6538 SERIES AIR CONDITIONERS. DAMAGE TO PRINTED CIRCUIT BOARD MAY RESULT.

WARNING - SHOCK HAZARD

To prevent the possibility of severe personal injury or equipment damage due to electrical shock, always be sure the electrical power source to the appliance is disconnected.

CAREFULLY FOLLOW ALL INSTRUCTIONS AND WARNINGS IN THIS BOOKLET TO AVOID DAMAGE TO THE EQUIPMENT, PERSONAL INJURY OR FIRE.

WARNING

Improper installation may damage equipment, can create a hazard and will void the warranty.

The use of components not tested in combination with these units will void the warranty, may make the equipment in violation of state codes, may create a hazard and may ruin the equipment.

2. COMPONENT MATCH-UP

1. 6538 Series Two Ton High Efficiency Packaged Air Conditioner. (Reference specifications for model number breakdown and identification.)
2. 6636-3453 Electronic 12 VDC Wall Mounted Thermostat. This thermostat is pre-wired to two electrical connectors. Both the thermostat supply and control wiring can be quickly attached (plugged in) to the thermostat.
3. 6795C4351 35' thermostat cable with connector plugs for termination at both the air conditioner and electronic thermostat.

3. DEPICTION FIGURES

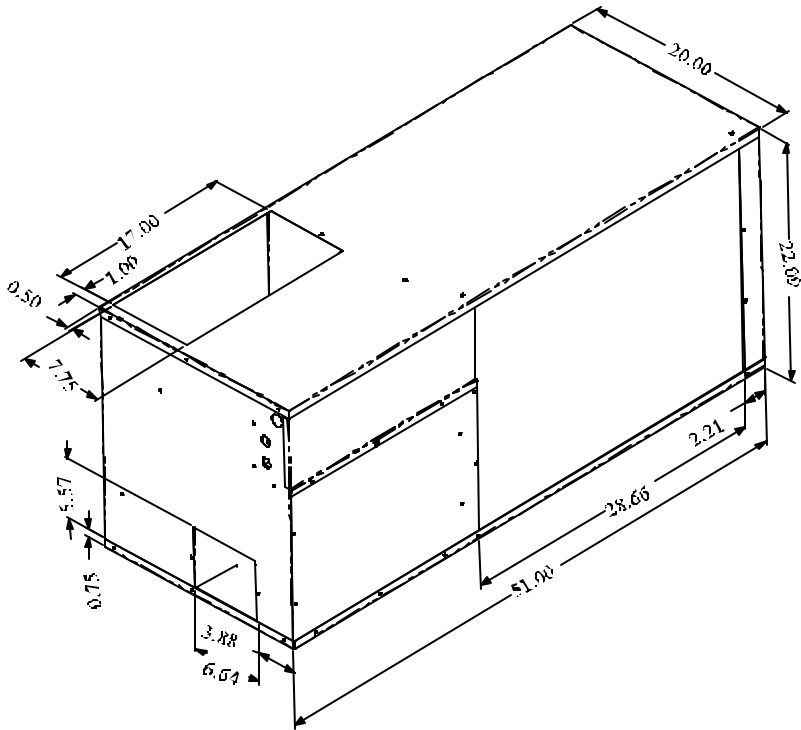

FIGURE 1

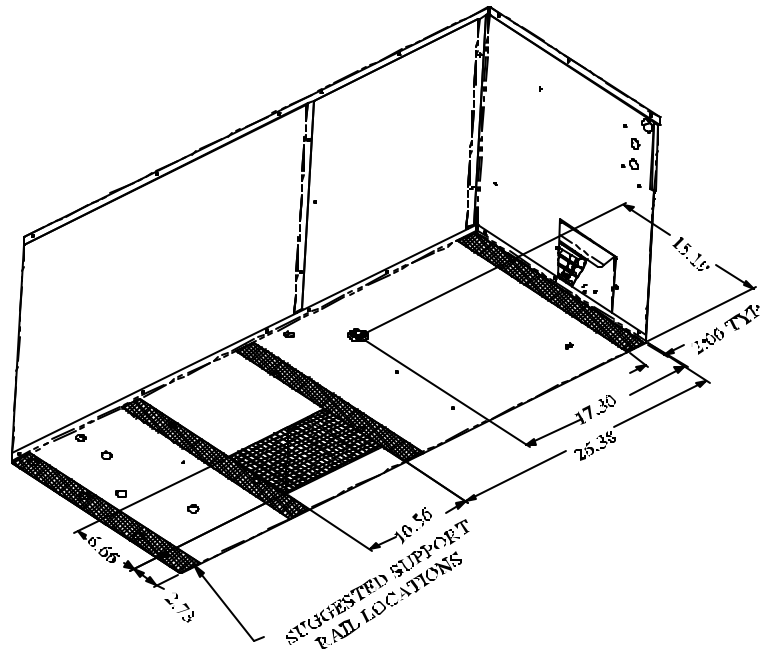

FIGURE 2

4. GENERAL INFORMATION

The 6538 Series Two Ton High Efficiency Packaged Air Conditioners are intended only for installation by RV manufacturers. The units are for “off the roof” installations and will usually be installed under the floor of the vehicle. It is understood that the vehicle manufacturer has provided an installation area which allows for floor cutouts and unit mounting without cutting vital frame members or electrical wiring and that structural members in the installation area will not create restrictions by passing through airways required by the air conditioner.

Conditioned air is delivered from the unit to the interior of the vehicle through ducting that is supplied and installed by the vehicle manufacturer. The system return air duct, return air filter and filter retainer are also supplied by the vehicle manufacturer.

The air conditioner is powered by two separate 115 volt 20 AMP electrical services.

The air conditioner is controlled by a 12 VDC electronic wall mounted thermostat. The vehicle manufacturer must provide the power source for the thermostat.

Avoid sliding the unit without the shipping block being attached. The condensate drain fitting extends slightly below the pan and will be damaged if not protected.

5. UNIT INSTALLATION CONDENSING AIR FLOW

The air conditioner draws in outside air for what is referred to as the outdoor coil. The air that is drawn across the outdoor coil is the outdoor air flow.

The installer is responsible for the proper ducting and routing of the outdoor air flow.

The outdoor air flow is drawn in through the side of the air conditioner (across the outdoor coil), and discharged out through the bottom of the appliance (through the discharge opening). Figures 1 and 2 show the location of both the outdoor coil and discharge air opening.

The unit must be installed so that the side that houses both the outdoor coil and the electrical box, faces towards the outer skin of the vehicle. The unit is installed this way so that:

- 1) the outdoor air flow will be drawn in from the outdoors through the side of the vehicle; and
- 2) the air conditioner can be serviced electrically.

To provide adequate air flow, the installer must adhere to the following guidelines:

- 1) Install the air conditioner so that the outdoor coil faces the outer skin of the vehicle; and
- 2) The outdoor air path to the coil should be as direct and non-restrictive as possible. RV

Products recommends placing the exterior condenser air flow grille into the side of the vehicle, directly in front of the outdoor coil. The installer must provide the exterior air opening and/or grille.

- 3) Any decorative grille or louver used as an opening should have 460 square inches of free area minimum.
- 4) Do not block or restrict the discharge air opening (located in the bottom of the air conditioner) with any flooring or bracing.
- 5) The air being used by the outdoor coil cannot be drawn from the underside of the vehicle. Seal or baffle the sides and bottom edge of the air conditioner to prevent the recirculation of air from underneath the vehicle. Recirculation of air across the outdoor coil will decrease both system performance and equipment life.
- 6) Do not install any other heat generating appliance in the same cavity as the air conditioner. Additional heat in this cavity will decrease system cooling performance. Overall package dimensions are shown in Figure 1. RV Products requires that a minimum of 4 additional inches be allowed at the wiring box end of the unit to allow for the installation of both the low and high voltage wiring.

- 7) Insure that neither the vehicle engine exhaust, on-board generator engine exhaust or water heater vent exhaust are pulled into the outdoor coil air flow. These hot gases will both: (a) increase system temperature reducing performance and equipment life; and (b) the collection of these gases chemical by-products will begin the chemical degradation of the surfaces they collect on.

In order to improve installation time and reduce down time when servicing, RV Products recommends using drawer slides for mounting the air conditioner.

This unit must be supported from below by angle iron, channels or RV frame members. These supports must be located under the air conditioner and kept within the areas shown (cross-hatched) in Figure 2. Support must be provided in the areas indicated to both secure the compressor and balance the system. Adding support outside of the indicated area may interfere with either the condenser air outlet or the condensate drain.

6. DUCT MOUNTING AND CONFIGURATION

The ducting for the air conditioner seals to the top. Cut-outs in the flooring provide passage for both the supply air and the return air.

The ducting configuration is the end outlet-top return configuration. Reference Figure 1. This system ducts the supply air out the end while the return air is drawn in through the top. With this configuration, one cut out will be required to match the end opening and another to match the top opening.

Under no circumstances will either of the openings or associated ducting be allowed to have a misaligned or smaller inner perimeter than either unit opening.

DANGER - SHOCK HAZARD

Do not drill or cut any openings into this air conditioner. Use only the pilot holes already provided. Drilling new openings and inserting screws may damage either the refrigeration circuit or electrical wiring causing possible equipment damage, personal injury or death.

When suspending the unit from flooring or frame members, a minimum of four threaded rods are required. Minimum rod diameter is 5/16". The support rods and hardware must be plated or equivalently protected against corrosion. All threaded fasteners should be provided with lock washers, "locktite", "double-nutted", or equivalently protected from vibration loosening after installation.

Condensation may at times splash out of the drain pan and drain from the unit corners. Therefore, do not mount the air conditioner above areas which might be damaged by exposure to moisture.

Upon completion of the installation, verify a minimum clearance of 14" from the bottom of the air conditioner to ground level.

To provide both vibration dampening for the unit and air tight seals for both supply and return air openings, RV Products recommends the use of foam gaskets.

Gaskets do not come with the unit, they must be provided by the installer. This allows the installer the option of either providing their own gaskets or not using gaskets and attach ducting directly to the air conditioner.

Attaching ducting directly to the air conditioner is not recommended unless the installer can provide a means for access and quick disconnect. Generally an installation of this type will require vehicle disassembly before some types of unit repair can be completed.

IMPORTANT

Regardless of installation configuration, insure that both duct connections are air tight. Loose or leaking connections can reduce system performance and allow gases, odors and dirt to be drawn in from outside the vehicle.

7. DUCT AND REGISTER SPECIFICATIONS

GENERAL INFORMATION

All supply air ducts, registers, return air ducts, return air filters and filter retainers must be supplied by the installer or vehicle manufacturer.

Any ducting (supply or return) exposed to a heat source or outdoor environment must be sealed and insulated to prevent heat gain and decreased system performance.

When ducting is attached directly to the unit cabinet, the installer must utilize the screw openings already provided.

RV Products strongly recommends that all air distribution systems be tested by the vehicle manufacturer in a floor mock-up prior to installation in the vehicle. In doing so, the vehicle manufacturer can insure that air volume, distribution and noise levels are optimized.

GUIDELINES FOR SUPPLY AIR DUCTING

Minimum free area inside the supply duct is 48 square inches. Ducting with more free area than 48 square inches will improve system performance and vehicle cool down time.

To decrease restriction and increase air flow, the ducting should make as few bends and turns as possible. When corners or turns are required, it is recommended that these turns be radiused and as gradual as possible.

The supply duct, unless made of an insulating material, must be insulated to prevent condensation from collecting on its exterior. Moisture condensation within the ceiling or wall cavity can damage insulation, stain vehicle interiors or create odors. 1/8", 3 pound density fiberglass or closed cell foam insulation has proven effective for this purpose.

Any ducting exposed to heat sources must be further insulated to prevent significant performance degradation due to heat gain. An example of an area capable of creating significant heat gain is the roof area which can sometimes experience temperatures of 160 degrees or more when exposed to direct sunlight. For ducting in or near the ceiling, it is impossible to provide "too much" thermal insulation.

GUIDELINES FOR SUPPLY REGISTERS

Total free area provided by the supply air registers must equal a minimum of 72 square inches.

Free area is the size of the opening(s) that remain in a grille or louvered panel after restrictions (the louvers) are subtracted. Most metal and plastic grilles average 30% to 60% open. That is the actual "free area" for the grille will be 30% to

60% of the total opening area.

GUIDELINES FOR RETURN AIR DUCTING AND FILTERS

All return air must be filtered. A 1-inch thick disposable fiberglass filter is recommended. A washable filter is acceptable if supported by a mesh or grille to prevent collapse.

Should the return air filter and filter retainer be located in the floor, a traffic duty grille will be required. The return air filter should be located in an area where:

- 1) drapes or bed sheets cannot block the opening;
- 2) the consumer can gain easy access for servicing.

This system is designed to operate without return air ducting. However, the fabrication and use of return air ducting is permissible.

When a return air duct is utilized, it is recommended that:

- 1) the length of the duct be kept to an absolute minimum;
- 2) the inner perimeter of the duct be kept as large as possible.

Return air ducting will contribute to the overall pressure and air flow loss of the system. Should the addition of return air ducting reduce air flow below acceptable levels, then either:

- 1) the supply air duct inner perimeter will need to be enlarged;
- 2) the supply air registers will need to be added;
- 3) the return air duct inner perimeter will need to be enlarged;
- 4) the return air duct will need to be shortened;
- 5) all of the above.

8. 115 VAC ELECTRICAL WIRING

1. WARNING - SHOCK HAZARD

To prevent the possibility of severe personal injury or equipment damage due to electrical shock, always be sure the electrical power is disconnected or off before beginning installation.

2. This unit contains a dual compressor refrigeration system. The two compressors can either cycle independently or operate in tandem with one another.

Each compressor is connected to a separate refrigeration circuit and a separate electrical circuit. The first compressor and refrigeration circuit to operate when the thermostat is calling is referred to as "1st Stage". The second compressor and refrigeration circuit to operate is referred to as "2nd Stage".

Both first and second stage systems require power from separate 115 volt electrical circuits. The two separate circuits connect to a high voltage terminal board in the air conditioner electrical box. The high voltage terminal board is specifically labeled for the two separate electrical connections. The markings are for "CIRCUIT 1" and "CIRCUIT 2".

"CIRCUIT 1" connections supply power for the 1st stage unit. "CIRCUIT 2" connections supply power for the 2nd stage unit.

On the terminal board, the termination point for both circuit 1 and 2 is equipped with two high-voltage wiring lugs. Each lug is identified with either the word "BLACK" or "WHITE".

DANGER - SHOCK HAZARD

To prevent electrical shock due to mis-wiring, adhere to the following procedure:

- 1) **Connect each circuits black (115V to GND) power lead to the "BLACK" high voltage lug;**
- 2) **Connect each circuits white (-0-V to GND) power lead to the "WHITE" high voltage lug;**
- 3) **Connect each circuits green or bare copper ground wire to the grounding lugs located in the electrical box. The high voltage grounding lugs for circuit 1 and 2 are located on either side of the high voltage terminal board.**

3. High Voltage Wiring Specifications

- A) U.L. approval requires the power supply to be copper conductors only with minimum #12 AWG.
- B) To prevent voltage drops greater than 10% during starting loads, insure that wiring size matches wire sizes shown on unit nameplate.

4. For circuit protection, adhere to the following guidelines (per circuit):

Time Delay Fuse - Maximum 20 AMP

Circuit Breakers –
(H.A.C.R. Type) - Maximum 20 AMP
(C.S.A.) - Maximum 20 AMP

5. High Voltage Routing Specifications

When routing the high voltage supply wiring for both circuit 1 and 2, the following guidelines must be followed:

- A) Route all wiring per applicable local and national electrical codes.
- B) Each circuit high voltage wiring must be routed through a separate opening in the outer cabinet of the wiring box. These openings are referred to as the "power wire entries". See Figure 1. RV Products provides these two openings, each opening is a 7/8" diameter opening.
- C) Each circuit wiring must be secured at the "power wire entry" by a U.L. listed "Rain Tight" or equivalent electrical conduit fitting. The fitting must be supplied by the installer or vehicle manufacturer.

DANGER

WHEN USING NON-METALLIC SHEATH SUPPLY CABLES (ROMEX, ETC.), STRIP SHEATH BACK TO EXPOSE 4-6 INCHES OF THE SUPPLY LEADS. STRIP THE INDIVIDUAL WIRE LEAD ENDS FOR WIRE CONNECTION (ABOUT 3/4" BARE WIRE). INSERT THE SUPPLY WIRES INTO THE ELECTRICAL CONNECTOR CLAMP. SHEATH MUST PROTRUDE

PAST CLAMP BUSHING INSIDE THE BOX. MAKE SURE SHEATH CABLE IS CENTERED IN CLAMP BEFORE TIGHTENING IT. DO NOT OVERTIGHTEN!! THIS COULD RESULT IN PINCHING THROUGH THE PLASTIC WIRE INSULATION AND CAUSE SHORTING OR "HOT" WIRES TO GROUND (SHOCK HAZARD). THE CLAMP IS INTENDED FOR STRAIN RELIEF OF THE WIRES, SLIGHT PRESSURE IS USUALLY SUFFICIENT TO ACCOMPLISH THIS.

IF OTHER THAN NON-METALLIC CABLES ARE USED FOR SUPPLY CONDUCTORS, APPROPRIATE STRAIN RELIEF CONNECTORS OR CLAMPS SHOULD BE USED.

IN NO CASE SHOULD CLAMPING OR PINCHING ACTION BE APPLIED TO THE INDIVIDUAL SUPPLY LEADS (NEUTRAL AND "HOT" WIRES).

- D) The installer must form a drip loop in the high voltage wiring routed between the "Rain Tight" electrical fitting and the high voltage terminal board wiring lugs. Do not allow excess wiring to contact electrical terminals, sharp screw ends or edging that can cut or damage the wiring insulation.
- E) After connecting the ground wire to the grounding lug, verify that the ground wire (which in some instances will be bare copper) cannot come into contact with any high voltage terminal.

9. THERMOSTAT AND 12 VDC WIRING

THERMOSTAT OPERATING AND WIRING REQUIREMENTS

The 6538 Series Two Ton High Efficiency air conditioner is designed to be operated from an RV Products electronic wall mounted thermostat. See component match-up section for thermostat part number and description. The thermostat is designed to operate 12 VDC controlled heating and air conditioning systems. The thermostat must be operated from a 12 VDC power source.

Maximum thermostat output for any load including the furnace control wire must not exceed one amp.

The thermostat is equipped with a replaceable fast-acting 2

6. Circuit 1 and 2 Origination Points

When both cooling systems (stage 1 and 2) cannot be powered from a single shore line, then the system must be wired as follows:

- A. Connect "CIRCUIT 1" to the circuit that is powered from the vehicle shore line. This allows stage 1 cooling to operate anytime the shore line is connected to either the local utility or the on-board generator.
- B. Connect "CIRCUIT 2" to the circuit that is powered from the on-board generator. When wired in this fashion, stage 2 cooling will operate only when the on-board generator is in operation.
- C. **DANGER - SHOCK HAZARD**

TO PREVENT THE POSSIBILITY OF SHOCK INJURY FROM APPLIANCE OPERATION:

THE WHITE WIRE MUST BE CONNECTED TO NEUTRAL IN THE SERVICE BOX ENTRANCE AND THE MECHANICAL GROUND MUST BE CONNECTED TO A GROUNDING LUG EITHER IN THE SERVICE BOX OR THE MOTOR GENERATOR COMPARTMENT.

amp fuse located on the base of the thermostat. The fuse is designed to open if the furnace is mis-wired or there is a short in the system. Before replacing fuse, the cause of the failure must be located and corrected.

IMPORTANT

Current draws in excess of one amp or shorting any thermostat wires can cause permanent thermostat failure.

The installer must provide the power source used to operate both the thermostat and its control circuits. This power source must provide one amp of continuous current at 12 VDC.

The thermostat is pre-wired at RV Products with two quick connect electrical receptacles. There is one 9 pin receptacle carrying the control wires required to operate the air conditioner, and a 3 pin receptacle carrying the two power supply leads and the one furnace control lead.

The thermostat 9 pin receptacle mates with a receptacle on one end of the RV Products 35' pre-wired thermostat harness. See component match-up section for harness part number and description.

The thermostat harness does not include the wiring for the 3-pin plug. Should the installer desire a total plug in system, then the mate and pins for this connection must be purchased separately. Both the receptacle and the pins are manufactured by AMP (Aircraft Marine Products, Inc., Harrisburg, PA). In most cases the parts can be obtained through a local supply house.

The AMP part numbers are:

- 1) 3 pin male receptacle #7-480700-0
- 2) female pin (for male receptacle) #350218-1

Should the installer desire to hard wire this connection rather than purchasing the receptacle, the three pin connector can be cut from the wire ends, the wires stripped and spliced to complete the required connections. For further wire identification and function, reference Chart 2.

CHART 1

WIRE COLOR	FUNCTION (each wire connects with)
RED	+12 VDC Supply Lead
BLUE	-12 VDC Supply Lead
WHITE	Furnace Control Wire (engages furnace)

IMPORTANT

When using wire nuts to complete electrical connections, always apply a U.L. approved electricians tape and secure the wire nuts to the wires in a workmanlike manner.

THERMOSTAT HARNESS

RV Products produces a pre-wired 35' thermostat wiring harness for this system. See component match-up section for harness part number and description. This harness consists of the wires required for operating the air conditioner and quick connect receptacles for both the thermostat and the air conditioner connections.

At the thermostat, the connection is completed with a square 9 pin receptacle that slides together and snap-locks in place.

When making this connection:

- 1) verify that the connectors are properly aligned
- 2) do not use excessive force when joining the connectors
- 3) verify that the connectors have snapped together on both sides.

The thermostat umbilical attaches to the unit with a rain-tight fitting. To install, remove the ring-nut from the rain-tight fitting and insert the wire end and fitting into the hole in the wirebox side. The ring-nut will now slide over the wire end and reinstall onto the rain-tight fitting threads. Tighten securely. It may be necessary to loosen the outer rain-tight nut and pull through additional sheathed cable to enable the connection to the printed circuit board receptacle. Re-tighten the outer nut after assembly. The wire end plugs into the receptacle on the wirebox printed circuit board. Insure that the plug "snap-locks" into the receptacle.

Routing of the thermostat wiring harness must comply with all local and national electrical codes. Collect any excess thermostat harness in the heat pump mounting compartment. Be sure to secure the excess wiring within the compartment. Coiling the excess harness into 3" diameter circles or larger is acceptable.

THERMOSTAT MOUNTING

Follow the instructions packed with the thermostat to select a location for thermostat mounting. Pay particular attention to choose a location which is not totally isolated from air currents and is not subject to direct discharge from an air register.

10. CHECKOUT

1. Before engaging power to any system, insure the following:
 - A) All tools have been removed from the equipment.
 - B) All wiring is attached, routed and properly secured.
 - C) All panels (both mechanical and electrical) are in place.
 - D) The thermostat system switch is placed into the "OFF" position and fan switch is placed in the "Auto" position.
 - E) All co-workers have been warned that the equipment is being energized.
2. System wiring may be checked by referring to the wiring diagram located on the back of the wiring box door.
3. Before beginning the checkout procedure, thoroughly read the instructions in either the thermostat installation instructions or in the owners manual provided with this product.

Keep in mind that the wall thermostat provides a 3 minute delay between off and on cycles.

There is also a 30 second delay between 1st and 2nd stage cooling. This is to prevent both compressors from starting simultaneously. To insure that the thermostat calls for both 1st and 2nd stage cooling, verify that the cool setpoint is well below actual indoor temperature.
4. After complying with steps 1 through 3, engage power to all systems and begin checkout procedure.
5. Test each thermostat function, such as fan modes, heat modes and cool modes to insure proper operation.



RV Products
A Division of Airxcel, Inc.
P.O. Box 4020
Wichita, KS 67204