



QUICK REFERENCE GUIDE

P.C. BOARD/WALL THERMOSTAT

FOR

6535*, 6537*, 6538*

TWO TON PACKAGED

HIGH EFFICIENCY

HEAT PUMPS

Note: This manual may also be used for 6535-871 series heat pumps if the 6535*3209 Replacement P.C. Board Kit has been installed in the unit.

RV Products
A Division of Airxcel, Inc.
P.O. Box 4020
Wichita, KS 67204
1-877-430-8084 (Service Center Locator)
1-316-832-4357 (Dealer Only Technical Help)
Web: www.rvcomfort.com
Support: www.rvpsupport@airxcel.com
Sales: www.rvpsales@airxcel.com

TABLE OF CONTENTS

I.	Wall Thermostat Installation and Operating Instructions - 6535*335	3
	Wall Thermostat Installation and Operation Instructions - 6536*335	5
II.	Heat Pump Operation Sequence - Cooling Mode	8
III.	Heat Pump Operation Sequence - Heating Mode	9
IV.	6535*320 Printed Circuit Board Function Chart	11
	Printed Circuit Board 9-Pin Thermostat Plug Connector	12
	Printed Circuit Board Indoor Blower Section	13
	Printed Circuit Board Compressor Section	14
	Printed Circuit Board Freeze Sensor Section	15
	Printed Circuit Board Outdoor Blower Section	16
	Printed Circuit Board Heating (Heat Pump) Section.	17
V.	Wiring Diagram - 6535 "A" 871 Series Two Ton High Efficiency Packaged Heat Pump.	18
	Wiring Diagram - 6535-671, 6535A671, 6535B871, 6537 & 6538 Series Two Ton High Efficiency Packaged Heat Pump.	19

I. WALL THERMOSTAT INSTALLATION AND OPERATING INSTRUCTIONS

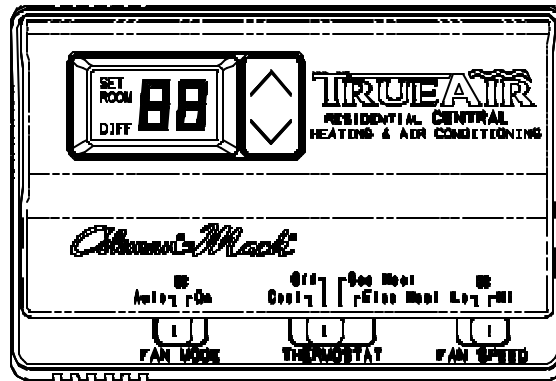

6535*335 Thermostat (Winnebago Only)

The display indicates room temperature and the word ROOM is shown on the LCD until the temperature selector is pressed; at which time the display temporarily indicates the setpoint temperature and the word SET is shown on the LCD. Each time the UP arrow is pressed, the setpoint will increase. Each time the DOWN arrow is pressed, the setpoint will decrease. Once the temperature selector button is no longer pressed for a few seconds, the room temperature will again be displayed, and the word ROOM will be displayed on the LCD.

In electric heat mode, if the heat pump is unable to satisfy the thermostat, DIFF will flash on the thermostat LCD when 2nd stage heating is required to satisfy the thermostat.

In gas heat mode, the gas furnace will provide the only source of heat and the heat pump is locked out.

NOTE

The temperature displays in degrees Fahrenheit as a factory set default (See Figure 2). To display in degrees Celsius, move the jumper marked "F" and "C" to bridge between middle pin and position "C", then cycle 12 volt power off and then back on.

6535*335 Thermostat Wiring

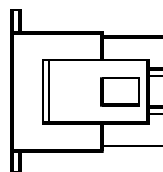
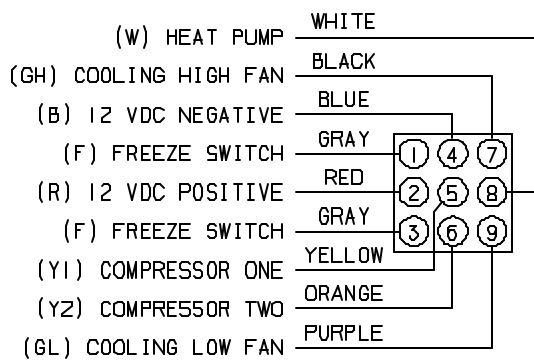

LIFELINE FROM UNIT TO THERMOSTAT PROVIDED BY R.V.P. A5 PART NUMBER: 6795C4351

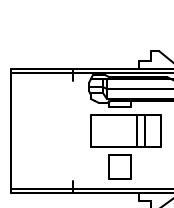
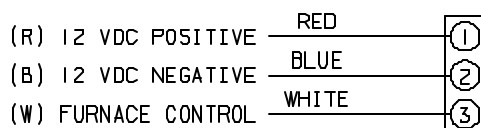

SOCKET TERMINAL x3 AMP P/N 350537-1

CAP HOUSING AMP P/N 1-480701-0

3 WIRE ASSEMBLY FROM POWER SUPPLY AND FURNACE TO THERMOSTAT MUST BE SUPPLIED BY O.E.M.

6535*335 2-Stage Heat Pump Thermostat Operation Table

	Mode Switch	Fan Mode Switch	Fan Speed Switch	Calling	Operation
1	Cool	Auto	Lo	No	No functions occur in this mode
2	Cool	Auto	Lo	Stage 1 1 Degree Above Set	ID fan low, compressor #1 and OD blower low cycle as needed
3	Cool	Auto	Lo	Stage 2 2 Degrees Above Set	ID fan low, compressors #1 and #2 and OD blower high cycle as needed
4	Cool	On	Lo	No	ID fan low continuous
5	Cool	On	Lo	Stage 1 1 Degree Above Set	ID fan low continuous, compressor #1 and OD blower low cycle as needed
6	Cool	On	Lo	Stage 2 2 Degrees Above Set	ID fan low continuous, compressors #1 and #2 and OD blower high cycle as needed
7	Cool	Auto	Hi	No	No functions occur in this mode
8	Cool	Auto	Hi	Stage 1 1 Degree Above Set	ID fan high, compressor #1 and OD blower low cycle as needed
9	Cool	Auto	Hi	Stage 2 2 Degrees Above Set	ID fan high, compressors #1 and #2 and OD blower high cycle as needed
10	Cool	On	Hi	No	ID fan high continuous
11	Cool	On	Hi	Stage 1 1 Degree Above Set	ID fan high continuous, compressor #1 and OD blower low cycle as needed
12	Cool	On	Hi	Stage 2 2 Degrees Above Set	ID fan high continuous, compressors #1 and #2 and OD blower high cycle as needed
13	Off	Auto	Lo or Hi	No	No functions occur in this mode
14	Off	On	Lo	No	ID fan low continuous
15	Off	On	Hi	No	ID fan high continuous
16	Gas Heat	Auto or On	Lo or Hi	No	No functions occur in this mode
17	Gas Heat	Auto or On	Lo or Hi	Stage 1	Heater will be energized to run
18	Gas Heat	Auto or On	Lo or Hi	Stage 2	There is no provision for 2 nd stage heat when operating in the gas heat mode
19	Elec Heat	Auto or On	Lo or Hi	No	No functions occur in this mode
20	Elec Heat	Auto or On	Lo or Hi	Stage 1	Heat pump will run ID fan high, both compressors, OD fan high and both reversing valves
21	Elec Heat	Auto or On	Lo or Hi	Stage 2	Heat pump will run ID fan high, both compressors, OD fan high and both reversing valves plus the heater will be energized to run

**INSTALLATION AND OPERATING INSTRUCTIONS
FOR 6536*335*
2 STAGE HEAT PUMP WALL THERMOSTAT**

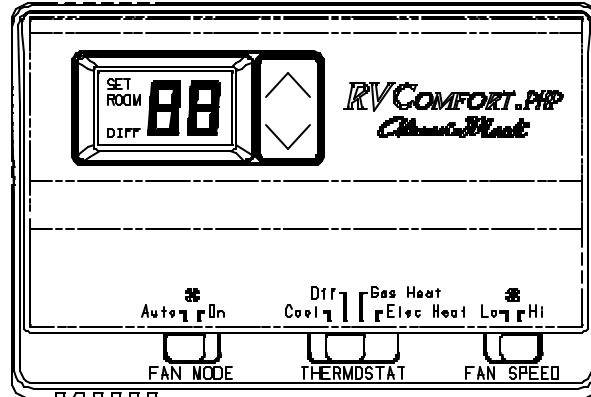

APPLICATION

The 6536*335* thermostat is intended for use with an RV Products 2 stage heat pump.

The thermostat connects to the heat pump with a 9 pin plug through a lifeline (RVP part number 6795C4351). The OEM (Original Equipment Manufacturer) must supply the 12 VDC wiring and the furnace control wiring which connects to the 3 pin plug on the thermostat. The OEM supplies the mating receptacle for the 3 pin plug. RV Products suggests the thermostat wiring be minimum 18 gauge. The furnace control circuit must not exceed 1 amp. The thermostat is equipped with a replaceable fast-acting 2 amp fuse located on the base of the thermostat. The fuse is designed to “open” if the furnace is mis-wired or there is a short in the system. Before replacing fuse, the cause of the failure must be located and corrected.

OPERATION

The display indicates room temperature and the word ROOM is shown on the LCD until the temperature selector is pressed; at which time the display temporarily indicates the setpoint

temperature and the word SET is shown on the LCD. Each time the UP arrow is pressed, the setpoint will increase. Each time the DOWN arrow is pressed, the setpoint will decrease. Once the temperature selector button is no longer pressed for a few seconds, the room temperature will again be displayed, and the word ROOM will be displayed on the LCD.

In electric heat mode, if the heat pump is unable to satisfy the thermostat, the heat pump goes into lockout. DIFF will display on the thermostat LCD indicating backup heating is required to satisfy the thermostat.

In gas heat mode, the gas furnace will provide the only source of heat and the heat pump is locked out.

NOTE

The temperature displays in degrees Fahrenheit as a factory set default (See Figure 2). To display in degrees Celsius, move the jumper marked “F” and “C” to bridge between middle pin and position “C”, then cycle 12 volt power off and then back on.

WIRING THE WALL THERMOSTAT

OEM must supply these mating parts to connect these thermostats per Figure 1. The plugs must be connected to motorcoach wiring harness before the base is secured to the wall.

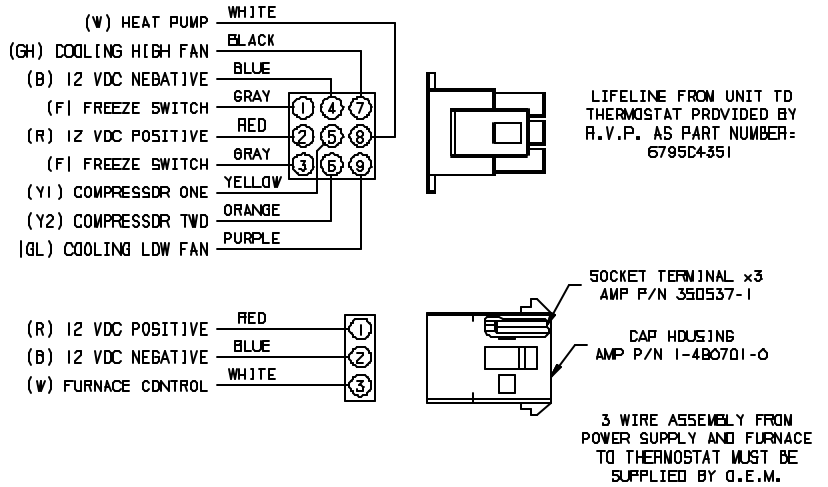

Heat Pump Example To Bring On Gas Furnace As Backup Heat

<u>Setpoint</u>	<u>Indoor Temperature</u>	<u>Operation</u>
70	70+	No functions occur
↓↓↓	69	Heat Pump turns on (Primary heat source)
	71	Heat Pump turns off (Thermostat satisfied)
	69	Heat Pump turns on
	65	Gas Furnace turns on, Heat Pump turns off (Heat Pump not able to satisfy Thermostat) (First strike for backup heat counter)
	71	Gas Furnace turns off (Thermostat satisfied)
	69	Heat Pump turns on
	65	Gas Furnace turns on, Heat Pump turns off (Heat Pump is again unable to satisfy Thermostat), (Backup heat counter reaches 3 rd strike and Heat Pump is locked out for 2 hours), backup heat counter is reset if Heat Pump is running for more than 20 minutes and does not call for backup heat
	71	Gas Furnace turns off (Thermostat satisfied)
	69	Gas Furnace turns on (Becomes Primary heat source)
	71	Gas Furnace turns off (Thermostat satisfied)
	↓↓↓	After 2 hour lockout
	69	Heat Pump turns on (Resumes as Primary heat source)
	65	Gas Furnace turns on, Heat Pump turns off (Becomes primary heat source) (Heat Pump is locked out for another 2 hours)
	71	Gas Furnace turns off (Thermostat satisfied)
	↓↓↓	After 2 hour lockout
	69	Heat Pump turns on (Resumes as primary heat source)
	71	Heat Pump turns off (Thermostat satisfied) (Backup heat counter is reset any time Heat Pump satisfies thermostat setpoint and does not need Gas Furnace)

The word "DIFF" will display on LCD when backup heat is operating and the heat pump is locked out. There is a 30 second delay between Stage 1 and Stage 2. There is also a 3 minute anti-short cycle delay time for cooling.

The chart below shows the system functions with the 6536*335* thermostat. After the entire air conditioning system (and furnace system) is installed, check each position function.

6536*335* 2-STAGE HEAT PUMP WITH BACKUP HEAT THERMOSTAT OPERATION TABLE

	Mode Switch	Fan Mode Switch	Fan Speed Switch	Calling	Operation
1	Cool	Auto	Lo	No	No functions occur in this mode
2	Cool	Auto	Lo	Stage 1 1 Degree Above Set	ID fan low, compressor #1 and OD blower low cycle as needed
3	Cool	Auto	Lo	Stage 2 2 Degrees Above Set	ID fan low, compressors #1 and #2 and OD blower high cycle as needed
4	Cool	On	Lo	No	ID fan low continuous
5	Cool	On	Lo	Stage 1 1 Degree Above Set	ID fan low continuous, compressor #1 and OD blower low cycle as needed
6	Cool	On	Lo	Stage 2 2 Degrees Above Set	ID fan low continuous, compressors #1 and #2 and OD blower high cycle as needed
7	Cool	Auto	Hi	No	No functions occur in this mode
8	Cool	Auto	Hi	Stage 1 1 Degree Above Set	ID fan high, compressor #1 and OD blower low cycle as needed
9	Cool	Auto	Hi	Stage 2 2 Degrees Above Set	ID fan high, compressors #1 and #2 and OD blower high cycle as needed
10	Cool	On	Hi	No	ID fan high continuous
11	Cool	On	Hi	Stage 1 1 Degree Above Set	ID fan high continuous, compressor #1 and OD blower low cycle as needed
12	Cool	On	Hi	Stage 2 2 Degrees Above Set	ID fan high continuous, compressors #1 and #2 and OD blower high cycle as needed
13	Off	Auto	Lo or Hi	No	No functions occur in this mode
14	Off	On	Lo	No	ID fan low continuous
15	Off	On	Hi	No	ID fan high continuous
16	Gas Heat	Auto or On	Lo or Hi	No	No functions occur in this mode
17	Gas Heat	Auto or On	Lo or Hi	Stage 1	Heater will be energized to run
18	Gas Heat	Auto or On	Lo or Hi	Stage 2	There is no provision for 2 nd stage heat when operating in the gas heat mode
19	Elec Heat	Auto or On	Lo or Hi	No	No functions occur in this mode
20	Elec Heat	Auto or On	Lo or Hi	Stage 1	Heat pump will run ID fan high, both compressors, OD fan high and both reversing valves
21	Elec Heat	Auto or On	Lo or Hi	Stage 2	Backup heater will be energized to run

II. HEAT PUMP OPERATION SEQUENCE COOLING MODE

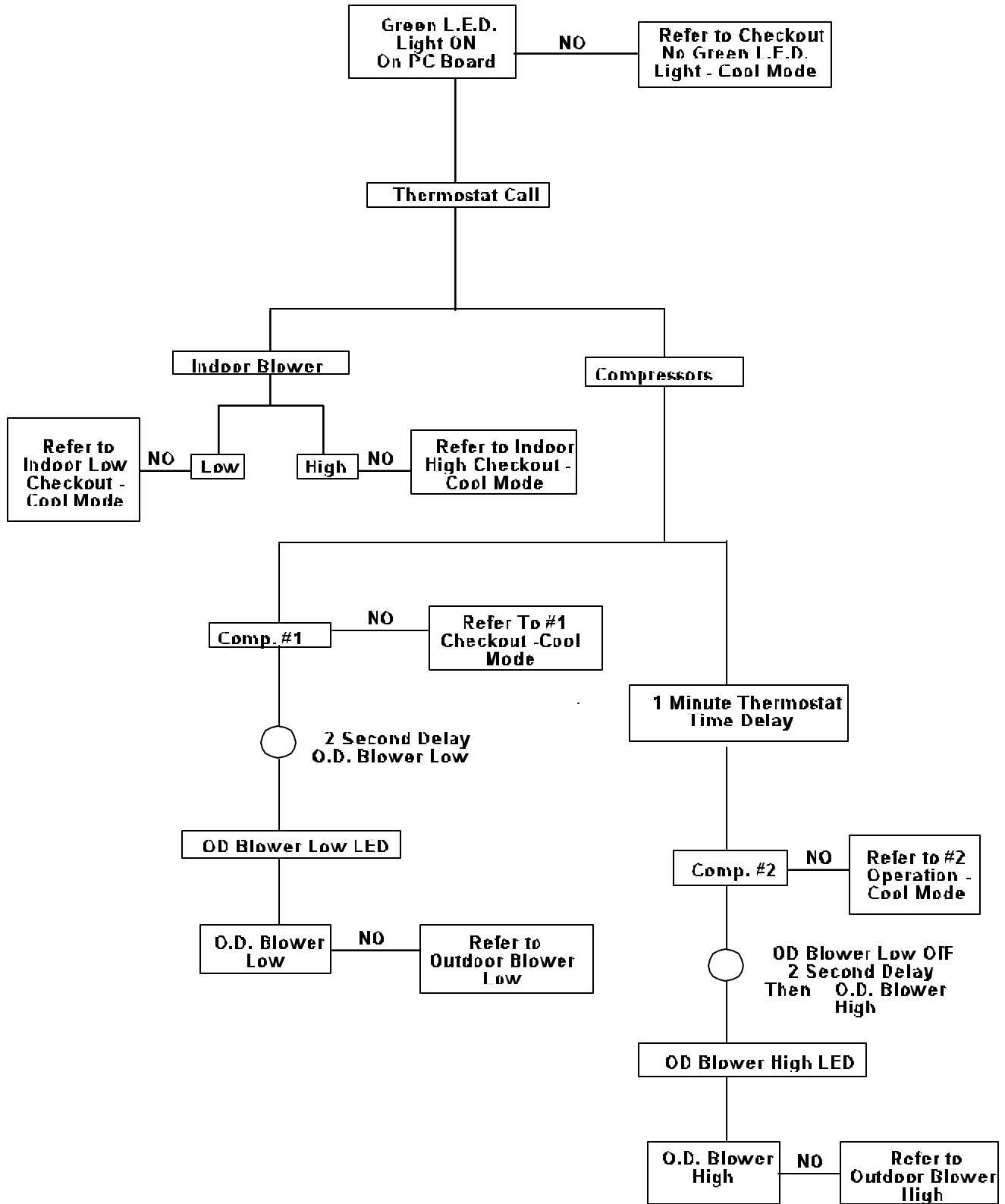

III. HEAT PUMP OPERATION SEQUENCE HEATING MODE

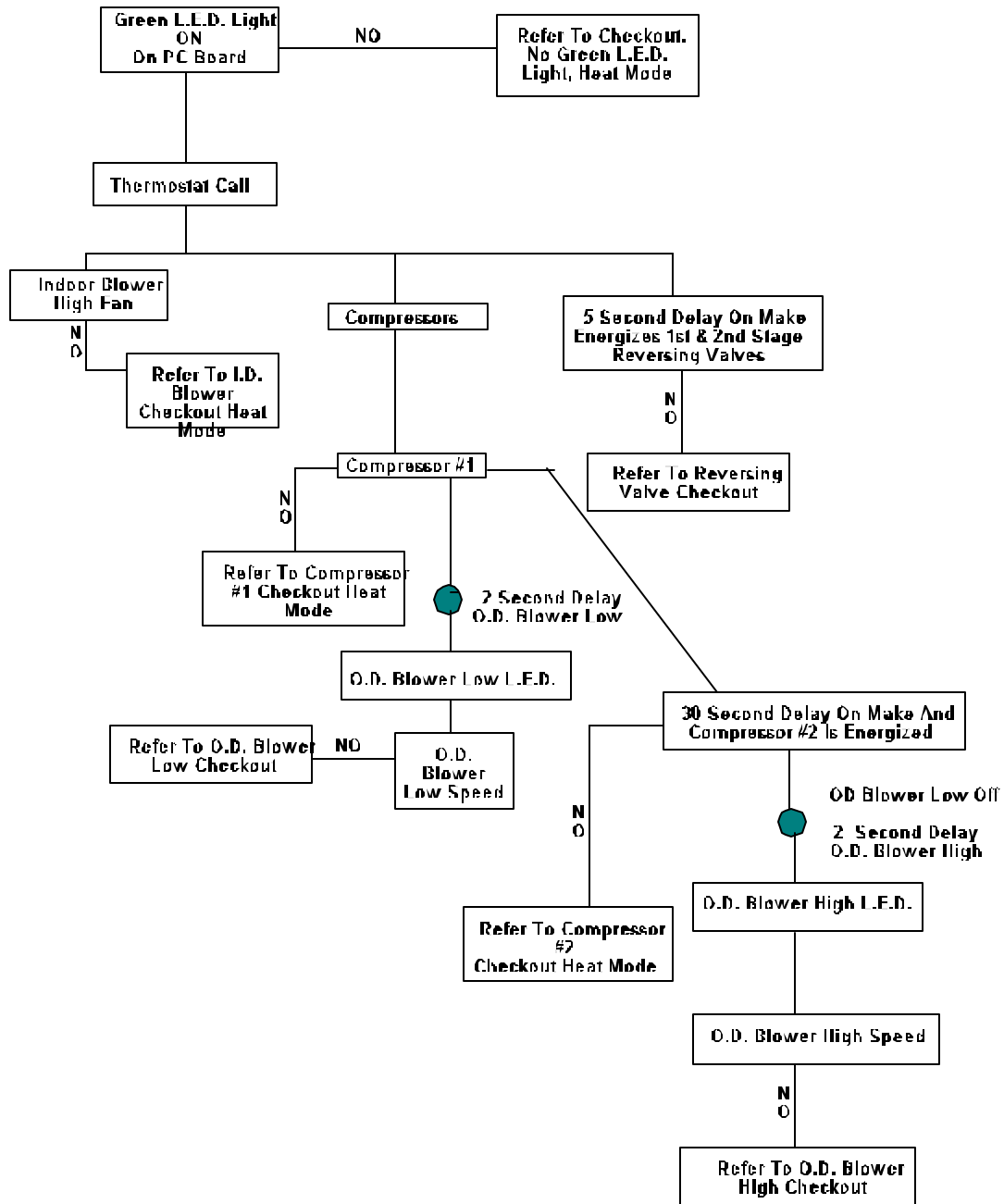

6535*320 PRINTED CIRCUIT BOARD FUNCTION CHART WINNEBAGO HIGH EFFICIENCY HEAT PUMP

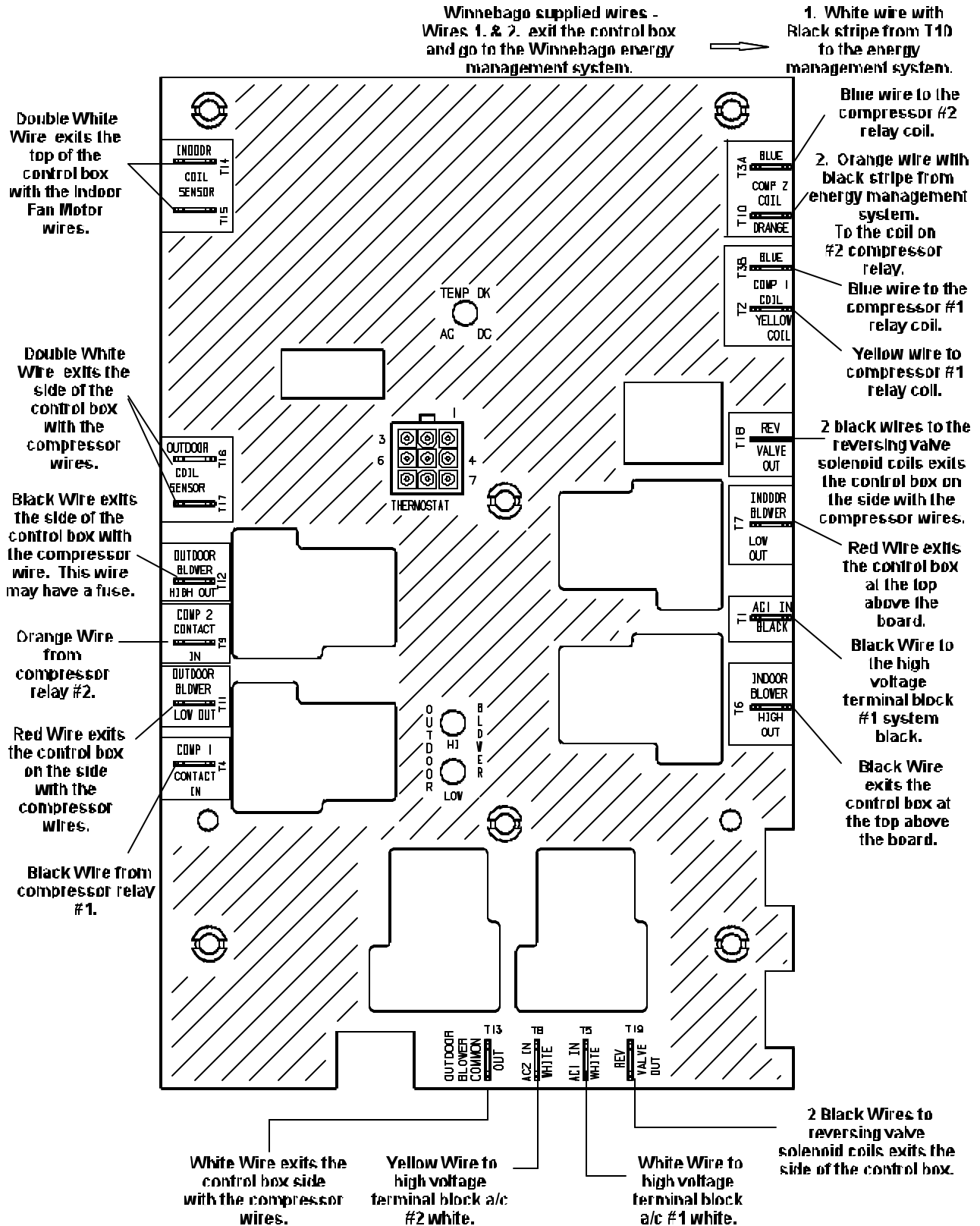

IV. 6535*320 PRINTED CIRCUIT BOARD FUNCTION CHART

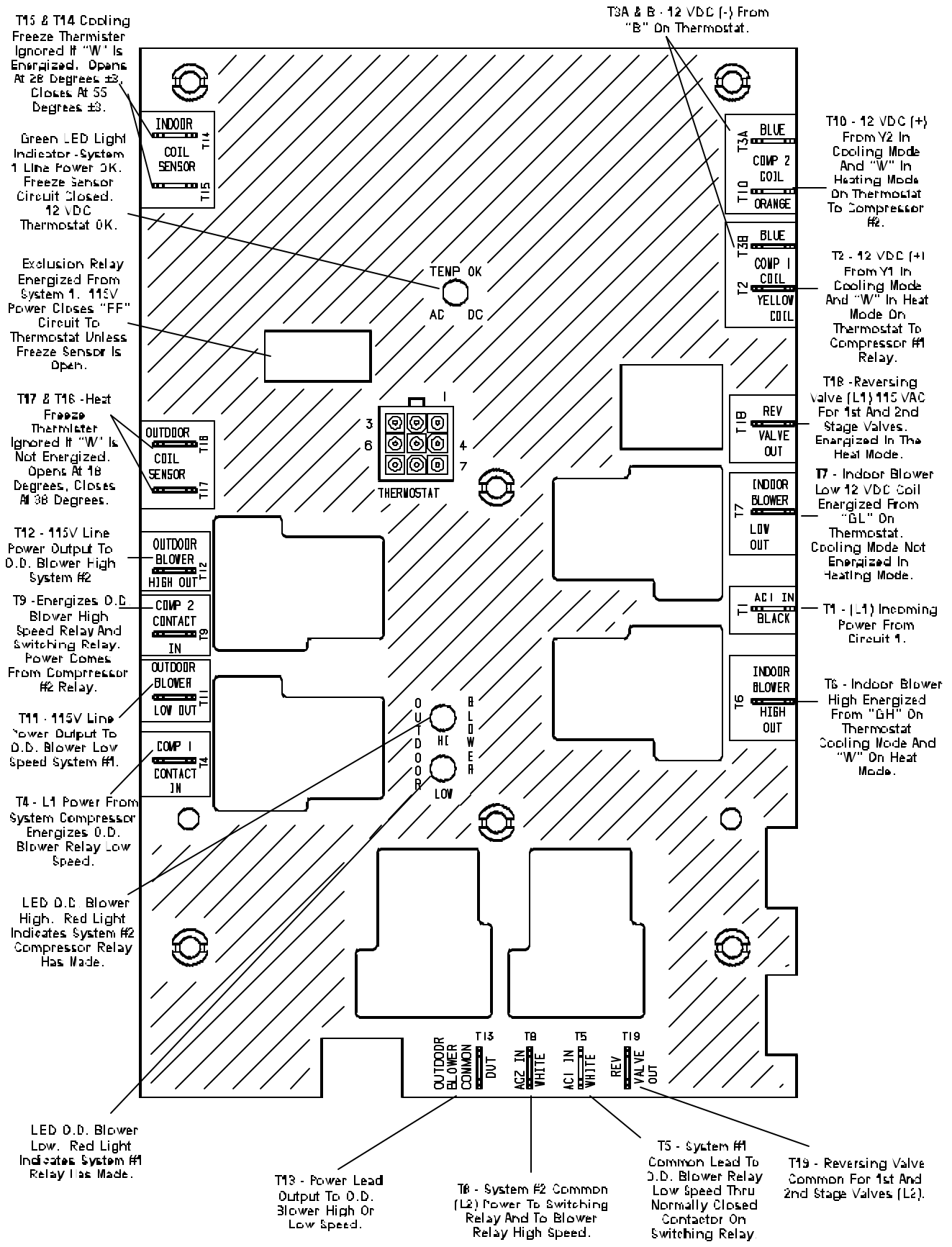

PRINTED CIRCUIT BOARD 9-PIN THERMOSTAT PLUG CONNECTOR

The figure above depicts the 9-pin printed circuit board socket as if you were looking straight at it.

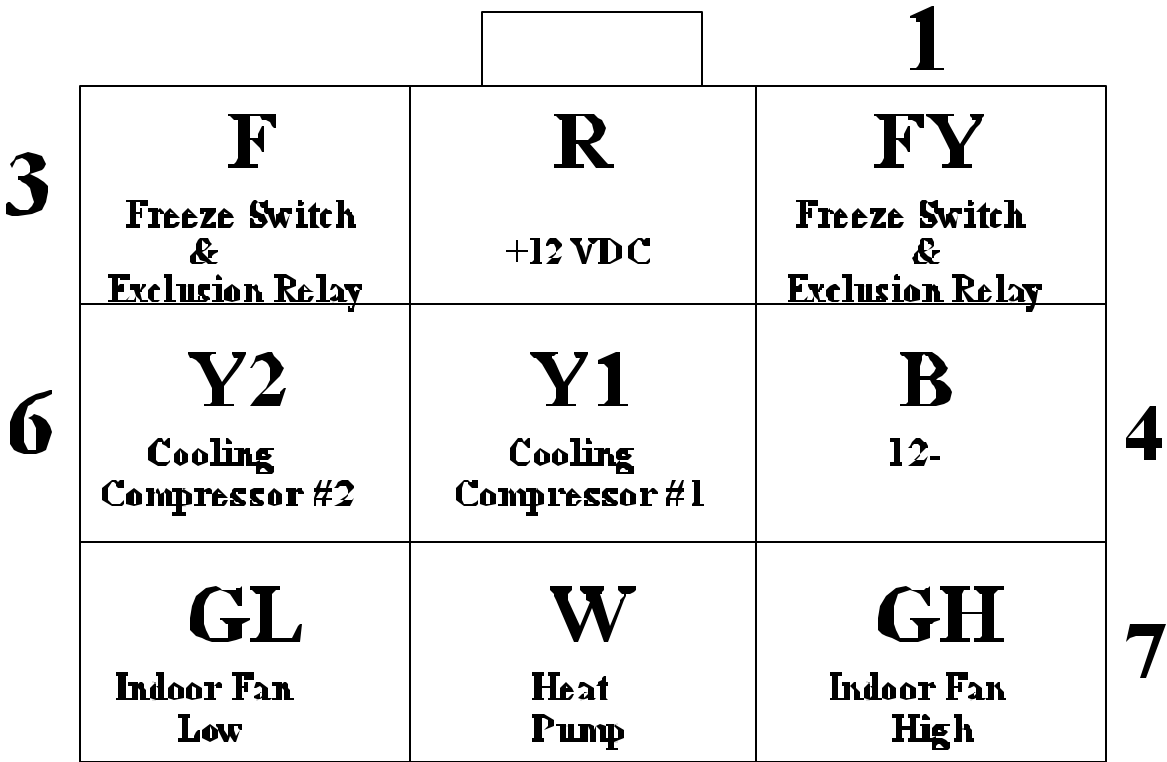

NOTE

1. Pin connections in this p.c. board socket are identical to those in the thermostat.
2. Low voltage connections to the p.c. board socket are subject to thermostat time delays.
3. The “Green Light” (freeze circuit) may be bypassed for troubleshooting purposes by bridging between terminals 1 & 3 (F&FY).

PRINTED CIRCUIT BOARD INDOOR BLOWER SECTION

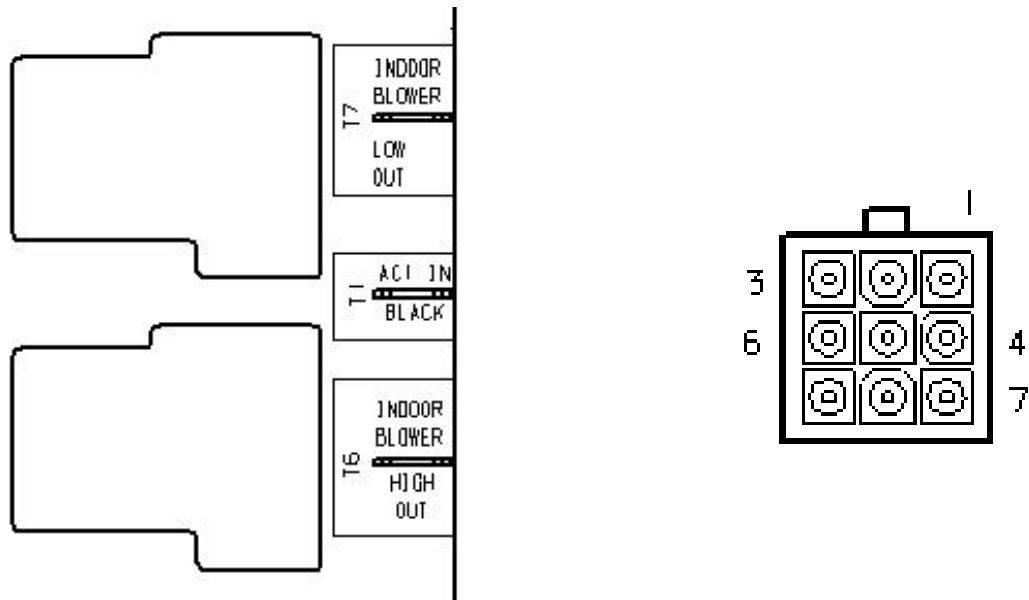

Note: Both High and Low Indoor Blower speeds operate on Circuit #1

HIGH SPEED INDOOR BLOWER OPERATION

1. Begins with a call from the thermostat, 12 volt positive (+) to terminal #7 (GH) in the 9-pin connector. (Black wire at the thermostat). The Ground (-) is Blue in terminal #4.
2. The High Speed relay closes on the board. 115 volts (HOT leg) signal should appear on T6, Indoor Blower High Out terminal. The 115 volt Neutral leg to the motor is not routed through the printed circuit board.
3. The 115 volts (HOT leg) power continues from terminal T6 to the High Speed motor tap.
4. The motor starts and runs on High Speed until the signal is lost from the thermostat.

LOW SPEED INDOOR BLOWER OPERATION

1. Begins with a call from the thermostat, 12 volt positive (+) to terminal #9 (GL) in the 9-pin connector. (Purple wire at the thermostat). The Ground (-) is Blue in terminal #4.
2. The Low Speed relay closes on the board. 115 volts (HOT leg) signal should appear on T7, Indoor Blower Low Out terminal. The 115 volt Neutral leg to the motor is not routed through the printed circuit board.
3. The 115 volts (HOT leg) power continues from terminal T7 to the Low Speed motor tap.
4. The motor starts and runs on Low Speed until the signal is lost from the thermostat.

PRINTED CIRCUIT BOARD COMPRESSOR SECTION

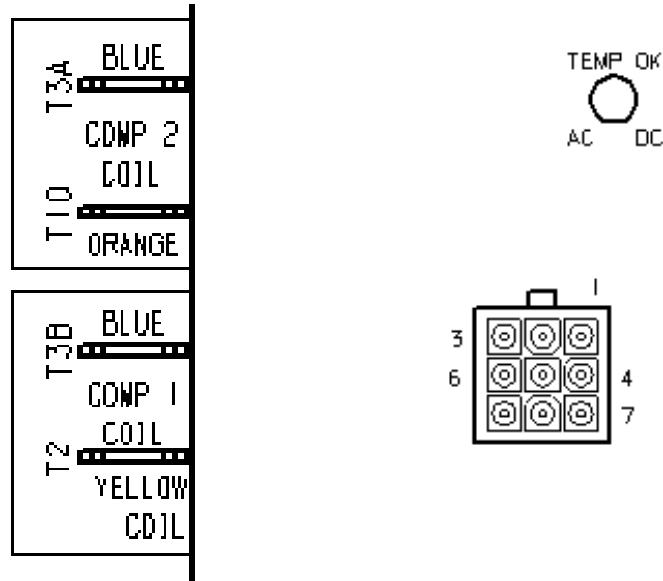

COMPRESSOR #1 COOLING OPERATION

1. Begins with a call from the thermostat, 12 volt positive (+) to terminal #5 (Y1) in the 9-pin connector. (Yellow wire at the thermostat). This call is subject to thermostat time delays. The Ground (12 VDC-) is Blue in terminal #4.
2. 12 VDC passes through the circuit board to terminals T3B and T2, Comp 1 Coil. (Subject to 115 VAC power through the Circuit 1 Exclusion Relay and the Freeze Switch).
3. 12 VDC exits terminals T3B and T2, Comp 1 Coil and goes to the Compressor #1 relay coil.
4. The Compressor Relay #1 closes.
5. Compressor #1 starts and runs until the compressor signal is satisfied at the thermostat. (What else might shut the compressor off?)

COMPRESSOR #2 COOLING OPERATION

1. Begins with a call from the thermostat, 12 volt positive (+) to terminal #6 (Y2) in the 9-pin connector. (Orange wire at the Thermostat). Subject to a 2-degree temperature differential and a thermostat time delay. The Ground (12 VDC-) is Blue in terminal #4.
2. 12 VDC passes through the circuit board to terminals T3A and T10, Comp 2 Coil.
3. 12 VDC exits terminals T3A (12 VDC-) and T10, (12 VDC+) Comp 2 Coil.
4. Terminal T10 (12 VDC+) is then routed through the **Winnebago Energy Management System** before it is connected to the Compressor #2 relay. T3A goes straight to the Compressor Relay #2 (Winnebago Only).
5. The compressor relay #2 closes. (Subject to available 115 VAC power).
6. Compressor #2 starts and runs until the compressor #2 signal is satisfied at the thermostat.

PRINTED CIRCUIT BOARD FREEZE SENSOR SECTION

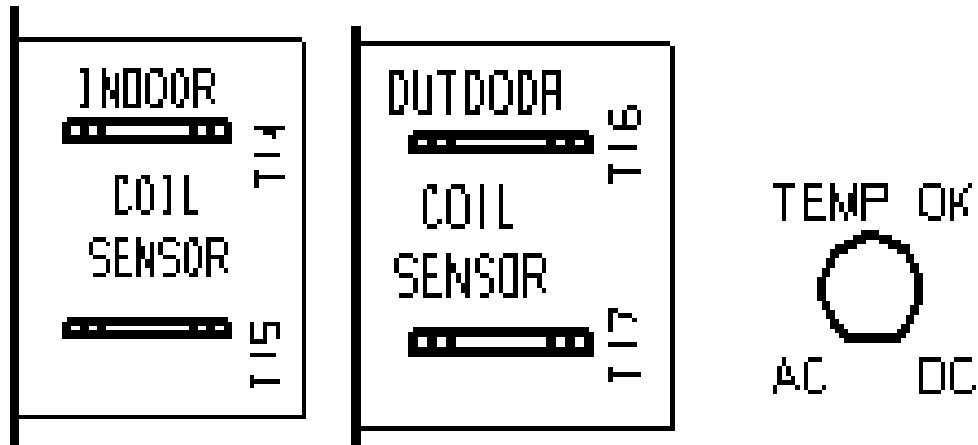

INDOOR COIL SENSOR

1. The Indoor Coil Sensor, T14 and T15 terminals are connected to a thermister located in the evaporator (Indoor) coil.
2. This sensor is an active part of the circuit only in the cooling mode.
3. This sensor is ignored if "W" (Electric Heat) is energized.
4. This sensor opens if the TEMPERATURE of the INDOOR COIL (not ambient air temperature) reaches 28 degrees F. The sensor closes at 55 degrees F.
5. If this sensor opens, the p.c. board will not output 12 volts DC to either Comp 1 (T2 and T3B) terminals or the Comp 2 (T3A and T10) terminals on the board.

OUTDOOR COIL SENSOR

1. The Outdoor Coil Sensor, T16 and T17 terminals are connected to a thermister located in the condenser (Outdoor) coil.
2. This sensor is an active part of the circuit only in the heating mode.
3. This sensor is ignored whenever "W" (Electric Heat) is NOT energized.
4. This sensor opens if the TEMPERATURE of the OUTDOOR COIL (not ambient air temperature) reaches 18 degrees F. The sensor closes at 38 degrees F.
5. If this sensor opens, the p.c. board will shut down all Heat Pump functions.

GREEN L.E.D. LIGHT OPERATION (FREEZE SENSOR)

1. If the GREEN light is on solid, everything is OK.
2. If the GREEN light is blinking slowly, the unit is in a 3-minute time delay mode.
3. If the GREEN light is blinking fast, there is either no line voltage to Circuit #1 or one of the thermisters are open.
4. If there is no GREEN light on, 12 VDC to the p.c. board has been lost.

PRINTED CIRCUIT BOARD OUTDOOR BLOWER SECTION

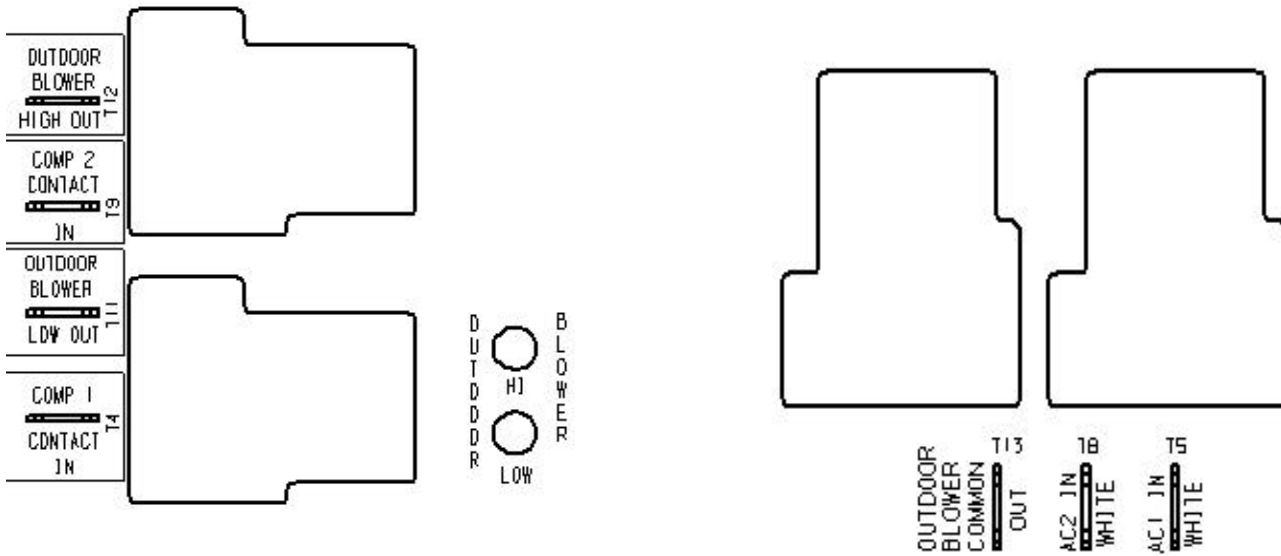

Note: These two sections of the p.c. board control both 115 volt (HOT and NEUTRAL) power legs to the OUTDOOR BLOWER.

LOW SPEED OUTDOOR BLOWER OPERATION

1. Begins with a 115 volt (HOT leg) signal received from the #1 Compressor Relay to the Comp 1 Contact In, T4 terminal on the p.c. board.
2. After a 2-second delay, 115 volts (HOT leg) signal should appear at the T11, Outdoor Blower Low Out terminal on the p.c. board. The 115 volt (NEUTRAL) leg is also completed to terminal T13, Outdoor Blower Common after the same 2-second time delay.
3. The Outdoor Blower starts and runs on Low speed until compressor #1 goes off or the second stage cooling is energized.

HIGH SPEED OUTDOOR BLOWER OPERATION

1. Begins with a 115 volt (HOT leg) signal received from the #2 Compressor Relay to the Comp 2 Contact In, T9 on the p.c. board.
2. Immediately the relays will open the circuits to T11, Outdoor Blower Low Out and T13, Outdoor Blower Common.
3. After a 2-second delay, 115 volts (HOT leg) signal should appear at the T12, Outdoor Blower High Out terminal on the p.c. board. Power is also re-applied to the 115 volt (NEUTRAL) leg, terminal T13, Outdoor Blower Common after the same 2-second time delay.
4. The Outdoor Blower starts and runs on High speed until compressor #2 goes off.

PRINTED CIRCUIT BOARD HEATING SECTION

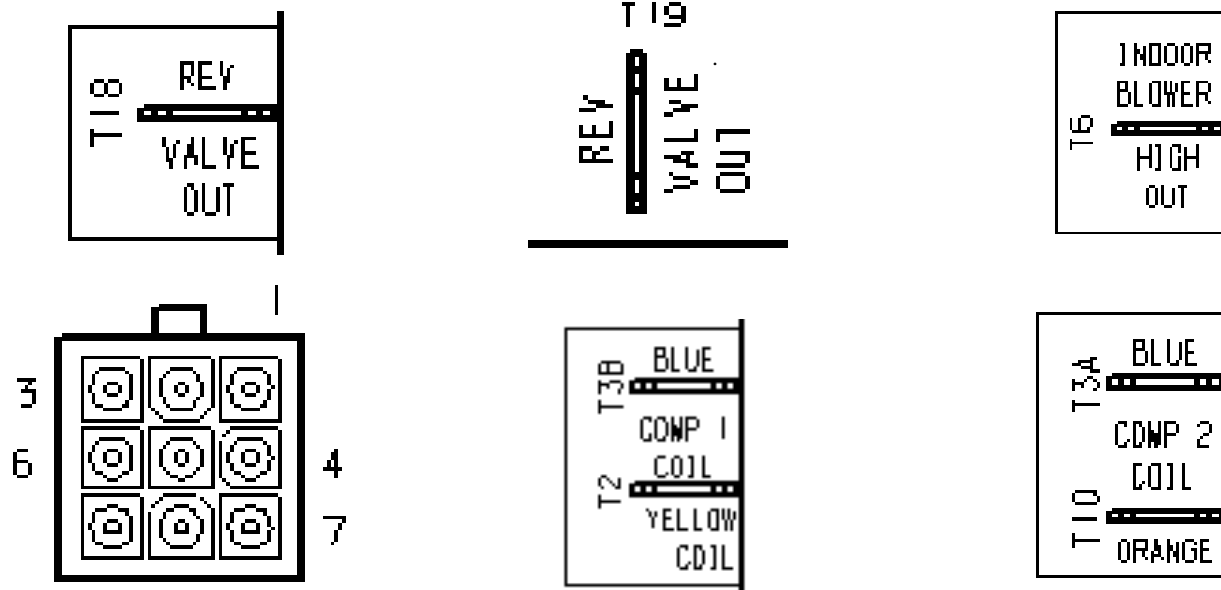

HEAT PUMP OPERATION (HEAT MODE)

1. Begins with a call from the thermostat, 12 volt positive (+) to terminal #8 (W) in the 9-pin connector. (White with Black stripe wire at the thermostat). The Ground (-) is Blue in terminal #4.
2. The p.c. board takes over at this time and controls all functions of the heat pump.
3. 115 VAC should appear between the T18 and T19 Rev Valve Out terminals.
4. This voltage continues to the reversing valve solenoid coils and switches both reversing valves to the heat position.
5. The High Speed Indoor Blower relay closes on the board. 115 volts (HOT leg) signal should appear on the T6, Indoor Blower High Out terminal. The 115 volt NEUTRAL leg to the motor is not routed through the printed circuit board.
6. The 115 volts (HOT leg) power continues from terminal T6 to the High Speed motor tap and the motor begins to run on High Speed.
7. 12 VDC passes through the circuit board to terminals T3B and T2, Comp 1 Coil. (Subject to 115 VAC power through the Circuit 1 Exclusion Relay and the Outdoor Coil Sensor).
8. 12 VDC continues from terminals T3B and T2, Comp 1 Coil to the Compressor #1 relay coil.
9. The Compressor Relay #1 closes and Compressor #1 comes on.
10. The Outdoor Blower starts on Low Speed 2-seconds later (See Outdoor Blower Section).
11. After a 30-second time delay, 12 VDC passes through the circuit board to terminals T3A and T10, Comp 2 Coil terminals.
12. Terminal T10 (12 VDC+) is then routed through the **Winnebago Energy Management System** before it is connected to the Compressor #2 relay. T3A goes straight to the Compressor #2 relay (Winnebago Only).
13. The Compressor Relay #2 closes. (Subject to available 115 VAC power). Compressor #2 starts and runs.
14. The unit continues in the Heating Mode until the thermostat is satisfied.

WIRING DIAGRAM - 6535 "A" 871 SERIES TWO TON HIGH EFFICIENCY PACKAGED HEAT PUMP

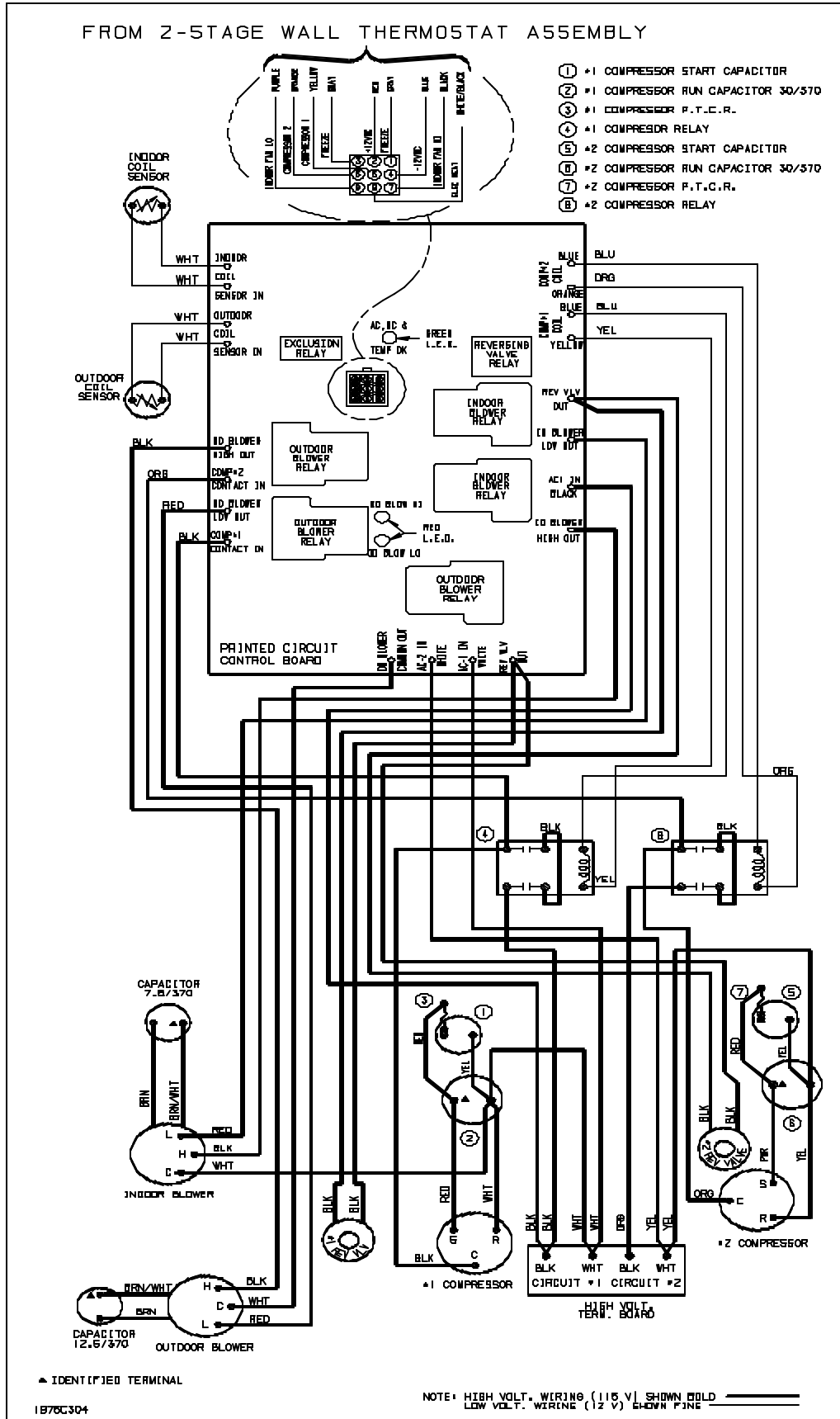

WIRING DIAGRAM FOR 6535-671, 6535A671, 6535B871, 6537 & 6538 SERIES TWO TON HIGH EFFICIENCY PACKAGED HEAT PUMP

