



RV Products Division

INSTALLATION INSTRUCTIONS

FOR

8330B933* COOL ONLY A/C
8330D935* HEAT READY A/C
8530C933* HEAT PUMP

FLUSH MOUNT CEILING PLENUM

TABLE OF CONTENTS

Warnings	2
Package Contents	2
General Information	3
Ceiling Plenum Installation Requirements	3
Supply Ducting and Registers	4
Routing Thermostat Wiring	5
Routing 115 VAC Wiring	6
Ceiling Plenum Mounting	6
Installing the Control Box and Heater Assembly	6

WARNINGS

IMPORTANT NOTICE

These instructions are for the use of qualified individuals specially trained and experienced in installation of this type equipment and related system components.

Installation and service personnel are required by some states to be licensed. **PERSONS NOT QUALIFIED SHALL NOT SERVICE THIS EQUIPMENT.**

WARNING

Improper installation may damage equipment, can create a hazard and will void the warranty.

The use of components not tested in combination with these units will void the warranty, may make the equipment in violation of state codes, may create a hazard and may ruin the equipment.

WARNING – SHOCK HAZARD

To prevent the possibility of severe personal injury or equipment damage due to electrical shock, always be sure the electrical power to the appliance is disconnected during installation.

CAREFULLY FOLLOW ALL INSTRUCTIONS AND WARNINGS IN THIS BOOKLET TO AVOID DAMAGE TO THE EQUIPMENT, PERSONAL INJURY OR FIRE.

NOTE

The words “Shall” or “Must” indicate a requirement which is essential to satisfactory and safe product performance.

The words “Should” or “May” indicate a recommendation which is not essential and not required, but which may be useful or helpful.

PACKAGE CONTENTS

- | | |
|-------------------------|---------------------------------------|
| 1) Wirebox Assembly | 1) Mount Frame |
| 1) Duct Divider Board | 1) Small Parts Package Consisting Of: |
| 1) Insulated Duct Plate | 4) Bolts |
| 1) Return Air Grille | 7) Screws |
| 1) Return Air Filter | 1) Wirebox Strain Relief |
| | 3) Wire Nuts |
| | 2) Wing Nuts |
| | 1) Cable Clamp |
| | 1) Freeze Sensor |
| | 1) Warning Card |

GENERAL INFORMATION

The flush mount ceiling plenum is designed for application in systems that utilize field fabricated (OEM supplied) cold air ducting. The ducting must be routed through the ceiling cavity (between the interior ceiling and roof). Ducting specifications are given in the section labeled "Supply Ducting and Registers".

This system utilizes a single, non-ducted centrally located return air opening. The return air opening is contained within the ceiling plenum. The ceiling plenum must be located directly below the roof opening used for mounting the roof top unit.

All manual controls have been removed from the ceiling plenum. They have been replaced with control relays. The relays are mounted in the electrical box of the ceiling plenum. The relays contain 12 VDC coils (which may be energized by a wall mounted thermostat), with contacts that control the 115 VAC used to power the roof top unit.

All air conditioning functions are controlled by the low voltage wall mounted thermostat. The thermostat controls a 12 VDC electrical circuit which is used to energize the relays in the ceiling plenum. The thermostat that Airxcel, Inc. provides for the system is a combination (Heat/Cool) thermostat. This thermostat is capable of operating up to 4 roof top air conditioners and furnaces with a 12 VDC control circuit of 1 amp or less (continuous current).

NOTE

To protect the wall mount thermostat from over-current damage, a 2 amp fuse is provided on the thermostat. It is recommended that a fuse be provided at the power supply to protect the thermostat wires up to the thermostat.

All air conditioning equipment is subject to freeze up when evaporator air flow is sufficiently reduced. Ducting of any

length creates potential for reduced evaporator air flow and system freeze-up. To protect both the installer and Airxcel, Inc. from conditions that promote reduced air flow and system freeze-up, Airxcel, Inc. has equipped the ceiling plenum compressor control circuit with a low temperature probe. The low temperature probe monitors the temperature of the air conditioner evaporator coil. When the temperature of the evaporator coil drops below 28 degrees F, the switch will open, stopping compressor operation. Compressor operation will resume once the evaporator warms to 55 degrees F.

IMPORTANT

The low temperature sensor is part of the ceiling plenum electrical circuit. The probe must be inserted into the evaporator coil of the roof top unit by the installer when bolting the ceiling plenum to the roof top unit.

The 8330B933* ceiling assembly mates with any 8000 series air conditioner to provide cool only operation. The cool only unit can easily be converted to add electric strip heater.

The 8330D935* ceiling assembly mates with any 8000 series air conditioner to provide electric heat as well as cooling.

The 8530C933* ceiling assembly mates with the 8500 series heat pumps. Backup electric heat is available as an optional kit (part number 9233*4551).

The ceiling plenum comes equipped with the following:

- 1) all hardware required for mounting and securing the roof top unit including a return air heater (heat/cool units)
- 2) a means of attaching the field fabricated ducting
- 3) the return air grille and filter

CEILING PLENUM INSTALLATION REQUIREMENTS

1. The ceiling plenum must be installed under the roof opening.

The ceiling plenum bolts below the roof top unit. Compression of the framed ceiling cavity between the roof top unit and the ceiling plenum is what holds both components in place.

2. Ceiling cavity depth (the measurement from the ceiling to the roof – maximum 6").
3. The 115 VAC service for the roof top unit must be routed into the ceiling plenum. To prevent wire pinching and to promote ease of installation,

allowances must be made for routing the 115 VAC supply wiring into the front of the roof opening.

4. Thermostat wiring must be run from the wall thermostat mounting location to the wirebox low voltage terminals. To prevent wire pinching and to promote ease of installation, allowances must be made for routing the low voltage wiring into the front of the opening.
5. The wirebox has a 9 pin receptacle extending from the front. This mates with the roof unit 115 volt electrical conduit. When making this connection,

verify that the plugs are properly aligned and have snapped together securely.

- 6. The wirebox also has a two pin receptacle which mates with the umbilical plug from the heater assembly (heat/cool units).
- 7. A low voltage terminal strip on the front of the box connects to the thermostat wires. The wires connect

by 1/4" quick connects. Airxcel, Inc. recommends using insulated quick connects. See chart below for wire colors and designations.

- 8. Provided with the ceiling plenum is a divider board which is used to separate the warm return air from the cold supply air.

Plenum Terminal Designation	Thermostat Wire Connection	Function of Low Voltage Terminal Extending from Ceiling Plenum
R+	Red	Provides +12 VDC to upper unit control box
Cool Shed (2 terminals)	White Jumper Wire	Removing jumper wire will allow system to be connected to N.C. contacts of a load shed system
Heat Shed (2 terminals)	White Jumper Wire	Removing jumper wire will allow system to be connected to N.C. contacts of a load shed system
Room (2 terminals)	Any	The remote room temperature sensor attaches here*
Freeze (2 terminals)	White	Freeze sensor attaches here
Gen	Any	Allows system to connect to an automatic start generator system
B-	Blue	Provides -12 VDC to upper unit control box
Sig	Purple	Communication line between upper unit control box and thermostat

* Zone 1 has option of using thermostat as room sensor

SUPPLY DUCTING AND REGISTERS

A. Ducting

- 1. The field fabricated supply ducting must attach to both sides of the ceiling plenum. A minimum of two ducts are required, with one duct attached to each side of the plenum (See Figure 1).
- 2. Each duct must have a minimum height of 1 1/2", maximum height cannot exceed 4 inches. Total free area inside each duct must be no less than 10 square inches.

Ten (10) square inches of free area per duct is the minimum requirement, larger ducting will improve air flow and system performance.

- 3. Where ducting secures to the ceiling plenum, maximum width is 8 inches.
- 4. All field fabricated cold air supply ducting must be insulated and must have a vapor barrier.

NOTE

To decrease restriction and increase air flow, the ducting should make as few bends and turns as possible. When corners or turns are required, we recommend that you radius the corners to keep air flow at a maximum.

IMPORTANT

Insulation reduces cooling loss and helps prevent water staining of the vehicle ceiling due to moisture condensation.

B. Registers

Supply (cold air) registers should have a minimum discharge area of 48 square inches per system, or 24 square inches per duct.

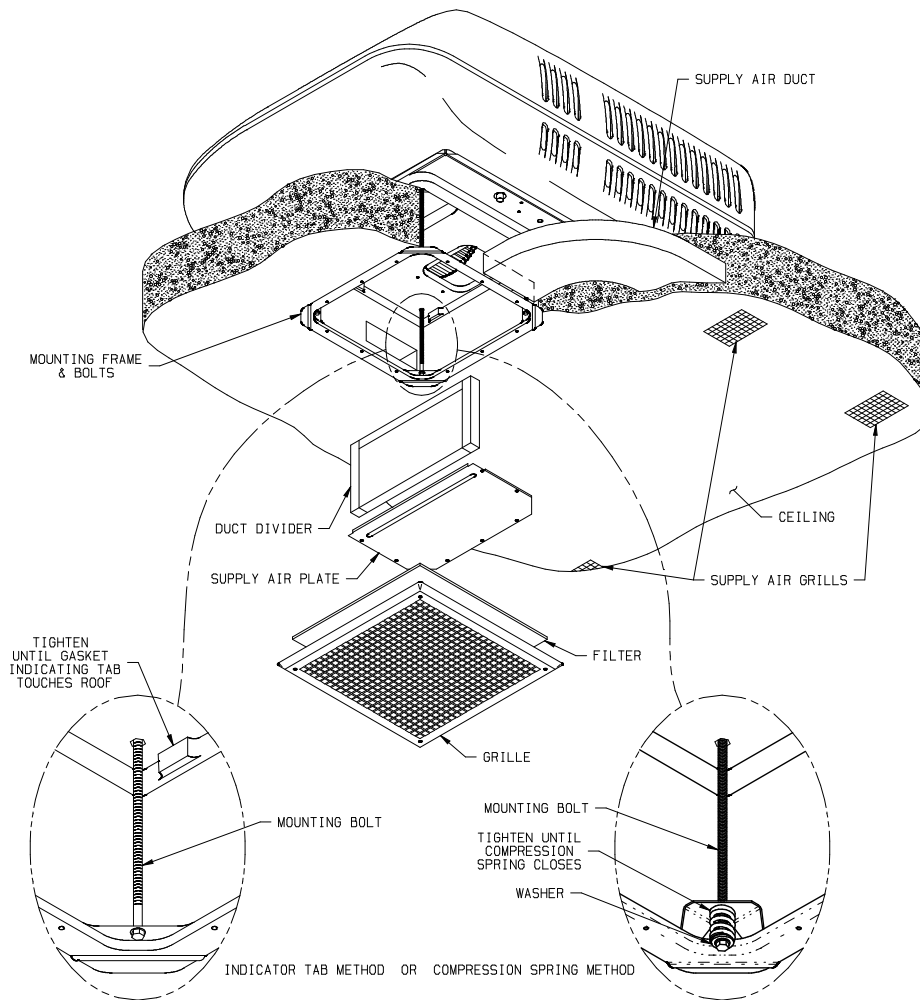

FIGURE 1

ROUTING THERMOSTAT WIRING

1. Following the instructions packed with the thermostat, determine a location for thermostat mounting.
2. Following Airxcel, Inc. low voltage wiring specifications and all local and national electrical codes: For 12 VDC thermostats, it is required that the thermostat 12 volt negative connection be routed directly from the converter or battery. It is highly desirable to provide 12 volt control power from the battery side of the converter. These precautions should prevent control problems.
 - A. Route the thermostat control wiring from the thermostat mounting location into the front of the ceiling plenum opening.
 - (1) Purple wire to communication signal (Sig)
 - (1) Any color for auto generator start (optional) (Gen)
 - (2) Any color for room temperature sensor (zone 1 optional, required for other zones)
 - (1) For each heating appliance (Up to 4)
 - (2) Any color for cool load shed (optional)
 - (2) Any color for heat load shed (optional)
 - B. See Figure 6 for wiring requirements for multiple zones.

These wires are as follows:

- (1) Red wire to +12 VDC circuit (R+)
- (1) Blue wire for -12 VDC circuit (B-)

3. Airxcel, Inc. low voltage wiring specifications:
 - A. All low voltage wiring should be no smaller than 18 gauge.
 - B. Low voltage wiring must be routed into the front side of the ceiling plenum opening.
 - C. Low voltage wiring should not be routed with high voltage wiring.
 - D. If low voltage and high voltage wires must cross, they should do so at right angles from one another.

ROUTING 115 VAC WIRING

Following Airxcel, Inc. high voltage wiring specifications and all local and national electrical codes, route the roof top unit 115 VAC supply wiring from its power source to the wirebox.

For lengths greater than 50', use #10 AWG or larger copper conductors. Match to the overcurrent protection device provided.

High Voltage Wiring Specifications based on Minimum Overcurrent Protection Device Amperage – (see upper unit nameplate)

Circuit Protection – Refer to upper unit nameplate.

1. U.L. requires copper conductors only with minimum #12 AWG when using the minimum recommended overcurrent protection device. Higher rated devices or longer wiring runs will require #10 AWG or greater copper conductors.
2. To prevent voltage drops greater than 10% during starting loads, adhere to the following guideline:

High Voltage Wiring Specifications based on Overcurrent Protection Device rated higher than the minimum required (see upper unit nameplate)

Follow all local and NEC (National Electrical Code) for proper sizing of wire AWG based on Overcurrent Protection Device selected and the length of the wiring run to the air conditioner.

CEILING PLENUM MOUNTING

Mounting (Refer to Figure 1)

1. Place the air conditioner over the roof opening centering the opening in the basepan with the ceiling opening.
2. Position the mount frame into the ceiling opening (See Figure 1).
3. Using the four bolts provided, secure the mount frame to the roof top unit by assembling the bolts up through the clearance holes of the mount frame and into the bottom of the roof top unit (See Figure 1). Tighten bolts only to bring gasket indicating tabs or shelf even with roof.
4. Secure mount frame to ceiling with screws.

INSTALLING THE CONTROL BOX AND HEATER ASSEMBLY

All control boxes install by one of two methods.

1. Remove the control box assembly's cover which is held by two sheet metal screws.
2. Set the "zone" jumper to the proper zone position for the particular position the air conditioner or heat pump will be in the coach (**Refer to Figure 2 – Zone 1 is shown**). Zones should be numbered from the front to the back of the coach with Zone 1 in front.
3. Set the "HP"/"NON HP" jumper to "HP" if the unit is a heat pump or to "NON HP" if the unit is not a heat pump (**Refer to Figure 2 – Non HP is shown**).
4. Feed the field lead wires and ground through the strain relief found with the control box then through the 7/8" hole in the side of the box.

5. Wire nut the black 12-gauge field power conductor to the stripped black 12-gauge wire in the control box.

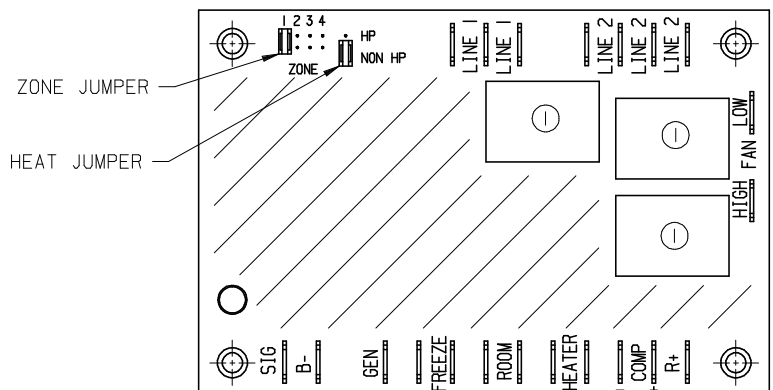

FIGURE 2

6. Wire nut the white 12-gauge field power conductor to the stripped white 12-gauge wire in the control box.
7. Wire nut the ground field power conductor to the stripped green ground wire in the control box.
8. Insure that no bare wires can come into contact with live electrical parts and that wire cannot be pinched between the control box sides and lid. Insert the strain relief into the control box entry hole to secure the field wiring. Reinstall the control box lid.
9. Mount control box in upper unit return air compartment.

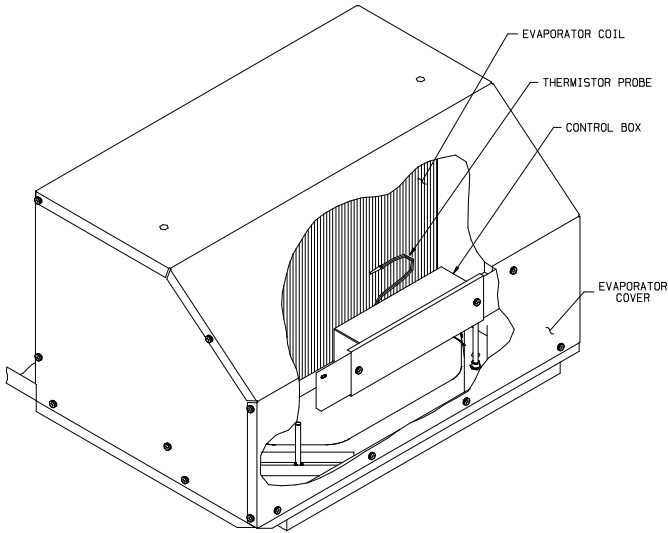

FIGURE 3

Refer to Figure 1

1. Measure the distance between the ceiling and the upper unit basepan, add ½” to this measurement and using this calculated value, cut the duct divider assembly board to this height. **ALWAYS CUT OFF THE BOTTOM EDGE (THE EDGE WHICH IS NOT PROVIDED WITH A FOAM STRIP).**
2. Carefully wedge this divider between the walls of the roof opening and up against the upper unit basepan. The upper unit mount gasket has a locator block on each side which locates the divider board.
3. Attach the insulated duct plate to the mount frame using the screws found in the small parts package.

The optional add-on heater assembly may now be installed on Heat Ready A/C and Heat Pump models.

Position the heater assembly into the return air opening as shown below. Insure that the set screw is retracted sufficiently to allow installation over the basepan extrusion.

The heater bracket **must be installed between the basepan and the plastic drain pan**. See Figure 7.

Tighten set screw to secure the assembly so as to prevent movement.

Insert the two-pin connector of the heater umbilical into the receptacle on the control box. Insure that the connector snaplocks into position.

TIE ALL WIRING TO INSURE NO CONTACT WITH THE HEATER OR ANY SHARP EDGES. KEEP IN MIND THAT HIGH VELOCITY AIR WILL BE ENCOUNTERED IN THIS AREA.

Attach the thermostat wires to Zone 1 control box per the illustration below (Refer to Figure 5):

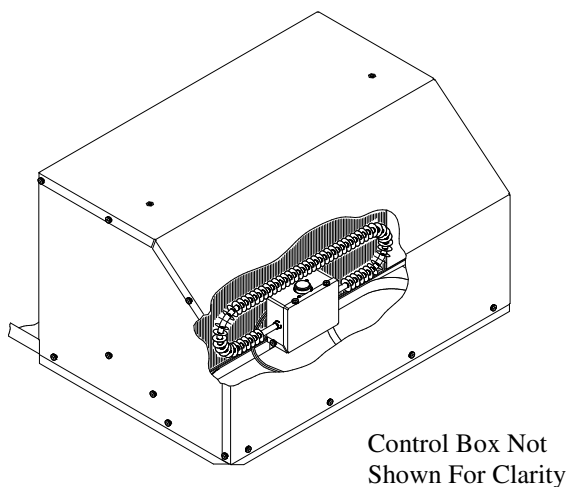

FIGURE 4

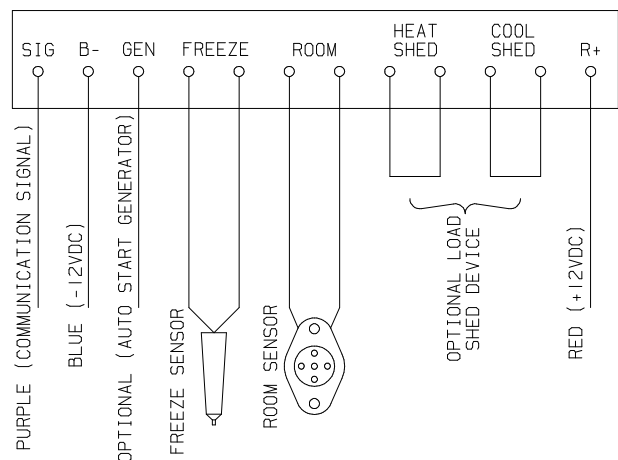
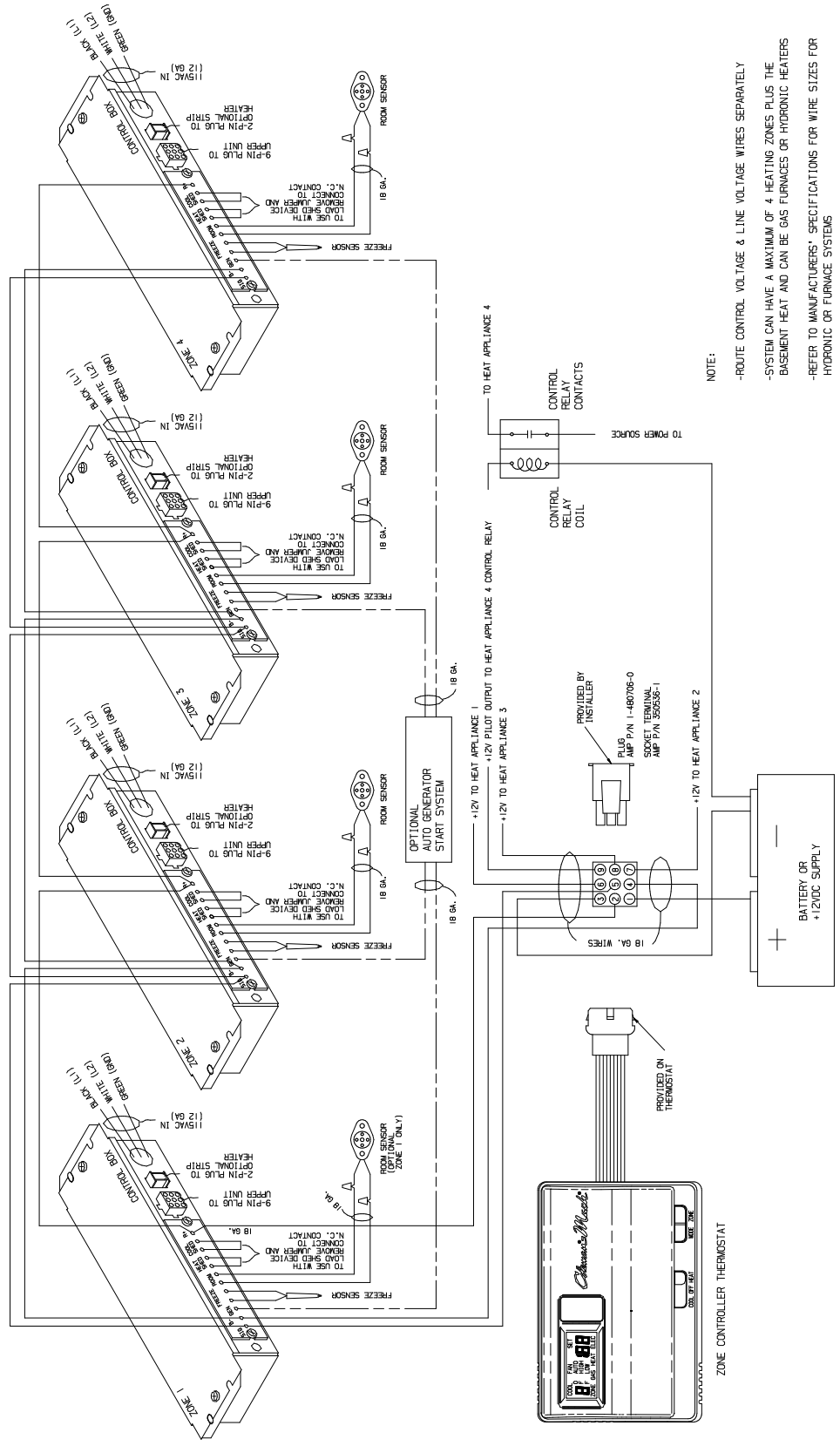

FIGURE 5

Note: The Zone System is shown with the maximum heating and cooling appliance connections.



NOTE:
 -ROUTE CONTROL VOLTAGE & LINE VOLTAGE WIRES SEPARATELY
 -SYSTEM CAN HAVE A MAXIMUM OF 4 HEATING ZONES PLUS THE BASEMENT HEAT AND CAN BE GAS FURNACES OR HYDRONIC HEATERS
 -REFER TO MANUFACTURERS' SPECIFICATIONS FOR WIRE SIZES FOR HYDRONIC OR FURNACE SYSTEMS

FIGURE 6

Zone 2 is wired in by jumpering from SIG, B- and R+ on Zone 1 box to Zone 2 box. Zone 3 is wired in by jumpering from SIG, B- and R+ on Zone 2 box to Zone 3 box. Zone 4 is wired in by jumpering from SIG, B- and R+ on Zone 3 box to Zone 4 box (See Figure 6).

The control box will be mounted by first removing the rubber wel-nuts (if supplied with the control box) and discarding the wing bolts. Position the control box over the screws and use the rubber wel-nuts (or wing nuts if supplied) to fasten the control box to the upper unit enclosure.

Insert the evaporator freeze sensor between evaporator fins near the bottom center of the evaporator and between the bottom two tubes (See Figure 2). Insert straight in until contacting the staggered tube directly in back of the insertion point. When contact has been made, elevate the exposed end of the sensor approximately 45 degrees, then continue insertion at a 45 degree angle until the sensor is completely embedded into the evaporator.

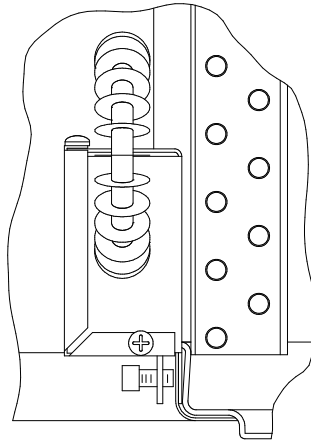

FIGURE 7

Gently fold all wiring into the electrical box while verifying that it is not either pinched or cut.

Complying with the warnings listed below, connect the 115 VAC supply wiring to its power source. Be sure all power remains off until beginning checkout procedure.

DANGER

TO PREVENT THE POSSIBILITY OF SHOCK INJURY FROM APPLIANCE OPERATION:

THE WHITE WIRE MUST BE CONNECTED TO NEUTRAL IN THE SERVICE BOX ENTRANCE AND THE MECHANICAL GROUND MUST BE CONNECTED TO A GROUNDING LUG IN THE SERVICE BOX OR THE MOTOR GENERATOR COMPARTMENT.

**Airxcel, Inc.
RV Products Division
P.O. Box 4020
Wichita, KS 67204**