



INSTALLATION INSTRUCTIONS

FOR

8330A731 & 8530A731

CEILING ASSEMBLY

**Airxcel, Inc.
RV Products Division
P.O. Box 4020
Wichita, KS 67204**

TABLE OF CONTENTS

1.	Warnings	2
2.	General Information and Requirements	2
3.	Package Contents	3
4.	Installing the Control Box	3
5.	Installing the Divider Board, Supply Duct and Mount Frame Assembly	4
6.	Installing the Grille and Filter	4

1. WARNINGS

IMPORTANT NOTICE

These instructions are for the use of qualified individuals specially trained and experienced in installation of this type equipment and related system components.

Installation and service personnel are required by some states to be licensed. **PERSONS NOT QUALIFIED SHALL NOT SERVICE THIS EQUIPMENT.**

WARNING

Improper installation may damage equipment, can create a hazard and will void the warranty.

The use of components not tested in combination with these units will void the warranty, may make the equipment in violation of state codes, may create a hazard and may ruin the equipment.

WARNING – SHOCK HAZARD

To prevent the possibility of severe personal injury or equipment damage due to electrical shock, always be sure the electrical power to the appliance is disconnected during installation.

CAREFULLY FOLLOW ALL INSTRUCTIONS AND WARNINGS IN THIS BOOKLET TO AVOID DAMAGE TO THE EQUIPMENT, PERSONAL INJURY OR FIRE.

NOTE

The words “Shall” or “Must” indicate a requirement which is essential to satisfactory and safe product performance.

The words “Should” or “May” indicate a recommendation which is not essential and not required, but which may be useful or helpful.

2. GENERAL INFORMATION AND REQUIREMENTS

This mount kit is designed to provide fore and aft (straight through) ducting. It is applicable to **47000, 48000 and 49000 Series Air Conditioners Only**. The control box mounts inside the upper unit return air opening. Recommended duct size is 2” x 6”. Supply registers should have an accumulated minimum discharge area of 48 square inches. The manufacturer supplied ducting must be insulated and covered with a vapor barrier to prevent

ceiling condensate staining. Insulation above the duct will minimize heat gain from the from the roof. The minimum recommended roof thickness with this system is 3 ½”. The upper unit and ceiling assembly mount on a square roof opening 14” to 15” on a side. The roof must be capable of supporting 110 pounds of static load. Keep in mind that dynamic loads exist in recreation vehicles.

3. PACKAGE CONTENTS

This package contains the following:

- | | |
|-----------------------------|---------------------------------------|
| 1) Steel Mount Frame | 8) Small Parts Package consisting of: |
| 2) Fiberglass Divider Board | (a) Mounting Bolt (x4) |
| 3) Insulated Supply Duct | (b) Mount Screw (x7) |
| 4) Insulated Duct Plate | (c) Wire Nut (x3) |
| 5) Control Box | (d) Freeze Sensor |
| 6) Air Filter | (e) Field Wire Strain Relief |
| 7) Grille | (f) Wing Nut (x2) |

4. INSTALLING THE CONTROL BOX

- Remove the control box assembly cover which is held by two sheet metal screws. Feed the field lead wires and ground through the strain relief found in the small parts package.
- Attach black supply conductor to black “pigtail” lead, white to white, and ground to green with wire nuts provided.
- Insure that no bare wires can come into contact with live electrical parts and that wires cannot be pinched between the control box sides and lid. Insert the strain relief into the control box entry hole to secure the field wiring. Reinstall the control box lid.
- Attach the thermostat wires to the control box per illustration below (Cool Only and Heat Pump box shown):
- Mount control box inside upper unit evaporator cover. Position the control box over the existing screws and secure the two wing nuts provided. The 47000 series requires that the control box is mounted with all wiring exiting the top.
- Insert the evaporator freeze sensor between evaporator fins near the bottom center of the evaporator and between the bottom two tubes. Insert straight in until contacting the staggered tube directly in back of the insertion point. When contact has been made, elevate the exposed end of the sensor approximately 45 degrees, then continue insertion at a 45 degree angle until the sensor is completely embedded into the evaporator.

Cool Only Box

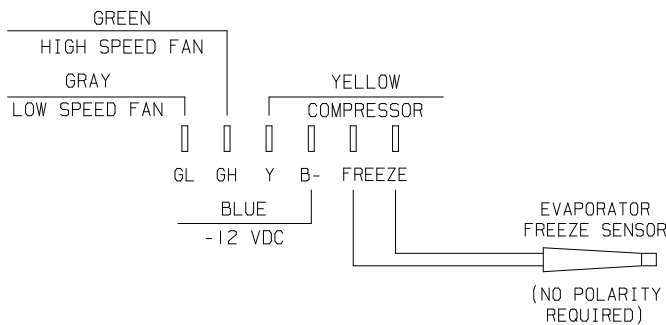

Heat Pump Box

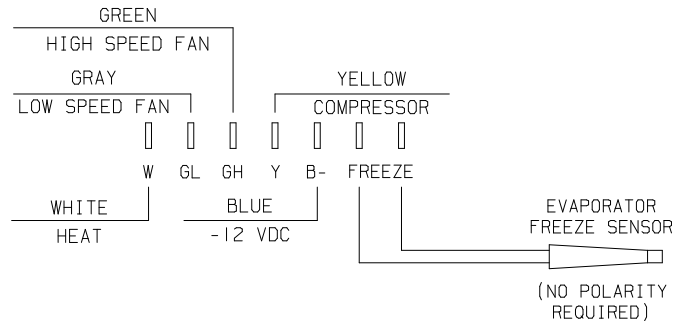

5. INSTALLING THE DIVIDER BOARD, SUPPLY DUCT AND MOUNT FRAME ASSEMBLY

SEE FIGURE 1

1. Note that the duct divider has been pre-cut to conform to the supply duct. These pre-cuts are centered in the divider board. The board width will not need adjustment, as the attached foam allows accommodation of any width between 14" and 15". Install as shown in Figure 1.
2. Insert the duct assembly into the divider board cutout. Gently ease the duct assembly forward until approximately 1" is inside the ceiling duct.
3. Locate the air conditioner mount gasket over the square opening in the roof.
4. Align the supply air plate under the opening. Attach with the seven screws found in the small parts package. See Figure 1.

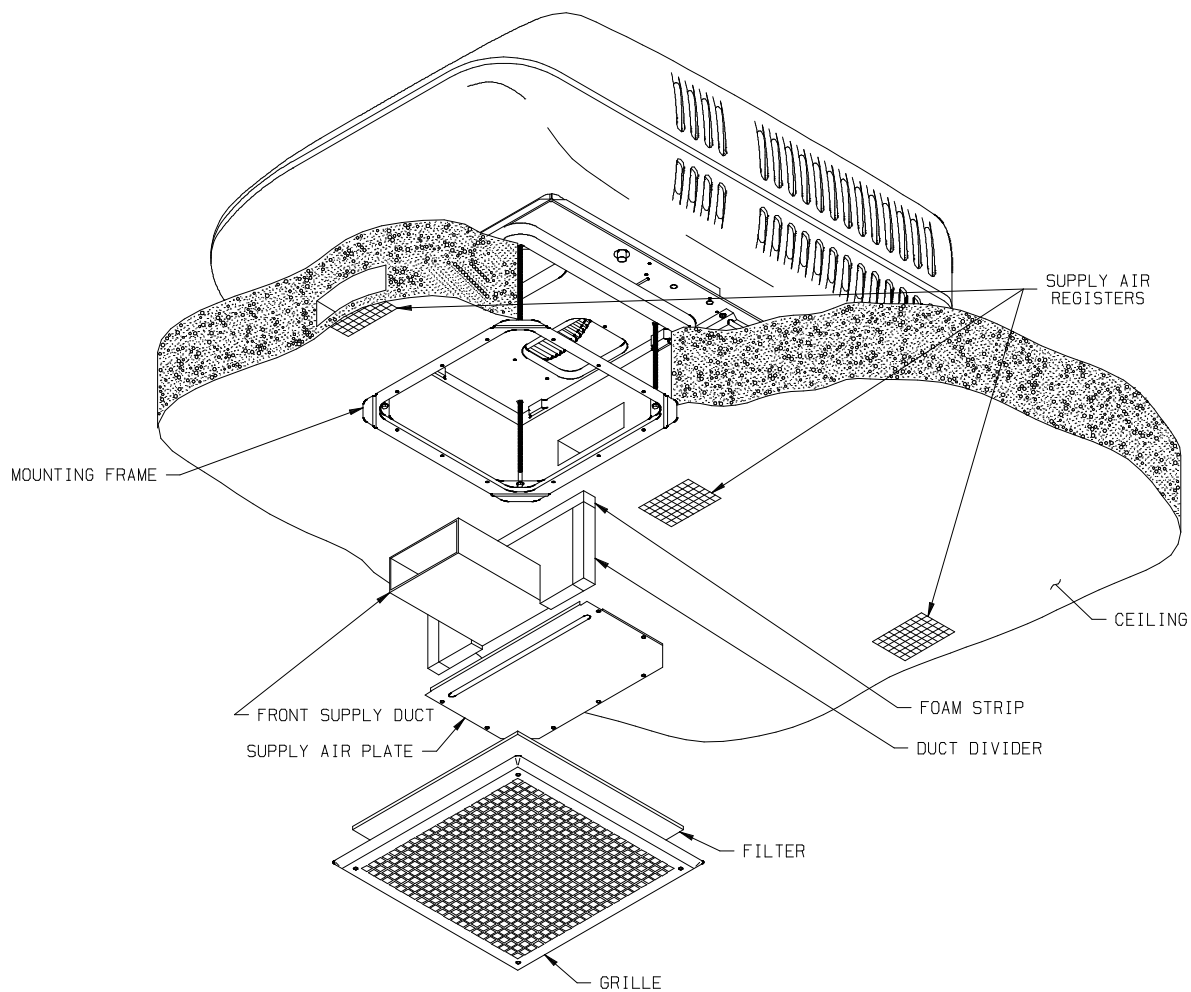

FIGURE 1

6. INSTALLING RETURN AIR GRILLE AND FILTER

Place filter on back side of return air grille. Lift grille into position, centered over roof opening. Insert one screw into each corner of the grille and secure to ceiling.