



SERVICE MANUAL

FOR

6636 SERIES

TWO TON HIGH EFFICIENCY

PACKAGED AIR CONDITIONERS

TABLE OF CONTENTS

1.	Warnings & Component Match-Up.....	2
2.	Unit Specifications.....	3
3.	Thermostat Operation & Specifications.....	4
4.	Thermostat Checkout.....	5
5.	Unit Depiction Figures.....	5
6.	Wiring Diagrams - Electronic Thermostat & A/C Unit.....	7
7.	Wirebox Component Checkout.....	9
8.	Indoor Blower Motor Removal.....	10
9.	Outdoor Blower Motor Removal.....	12
10.	Cap Tube Replacement.....	13
11.	Evaporator Coil Replacement.....	14
12.	Condenser Coil Replacement.....	15
13.	Compressor Replacement.....	15
14.	Electrical Flow Charts.....	16

1. WARNINGS

IMPORTANT NOTICE

These instructions are for the use of qualified individuals specially trained and experienced in installation of this type equipment and related system components.

Installation and service personnel are required by some states to be licensed. **PERSONS NOT QUALIFIED SHALL NOT INSTALL NOR SERVICE THIS EQUIPMENT.**

NOTE

The words "Shall" or "Must" indicate a requirement which is essential to satisfactory and safe product performance.

The words "Should" or "May" indicate a recommendation or advice which is not essential and not required but which may be useful or helpful.

WARNING - SHOCK HAZARD

To prevent the possibility of severe personal injury or equipment damage due to electrical shock, always be sure the electrical power to the appliance is disconnected.

CAREFULLY FOLLOW ALL INSTRUCTIONS AND WARNINGS IN THIS BOOKLET TO AVOID DAMAGE TO THE EQUIPMENT, PERSONAL INJURY OR FIRE.

WARNING

Improper installation may damage equipment, can create a hazard and will void the warranty.

The use of components not tested in combination with these units will void the warranty, may make the equipment in violation of state codes, may create a hazard and may ruin the equipment.

COMPONENT MATCH-UP

- | | |
|--|---|
| <p>1. 6636 Series Package Air Conditioner. (Reference specifications for model number breakdown and identification.)</p> | <p>2. 6636 Series Electronic 12 VDC Wall Mounted Thermostat. This thermostat is pre-wired to two electrical connectors. Both the thermostat supply and control wiring can be quickly attached (plugged in) to the thermostat.</p> |
|--|---|

2. UNIT SPECIFICATIONS

6636-871

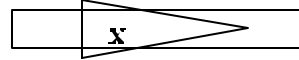

MODELNUMBER

SERIAL NUMBER

FOR OUTDOOR USE

USE THERMOSTAT 6636-345

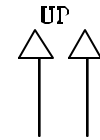

ELECTRICAL RATINGS: 115VAC, 60 HZ, 1 PHASE

CIRCUIT #1

CIRCUIT #2



2.4	FLA	ID. BLOWER MOTOR DATA H.P. 1/5	FLA	N/A
2.8	FLA	O.D. BLOWER MOTOR DATA H.P. 1/8	FLA	3.7

16.0	AMP	MINIMUM CIRCUIT CAPACITY	AMP	14.6
20	AMP	MAXIMUM OVERCURRENT PROTECTIVE DEVICE	AMP	20
21.0	OZ.	R-22 CHARGE WEIGHT	OZ.	21.0

#12	0' - 25'	MIN. SUPPLY CONDUCTOR GAUGE (COPPER)	0' - 25'	#12
#10	25' - 40'	UTILISER DES FILS D'ALIMENTATION EN CURVE	25' - 40'	#10
#8	40' - 63'		40' - 63'	#8

WEIGHT	200 LBS.
LENGTH	46"
DEPTH	21"
HEIGHT	18"

RV PRODUCTS
 A DIVISION OF AIRXCEL, INC.
 WICHITA, KS 67204

3. THERMOSTAT OPERATION AND SPECIFICATIONS

THERMOSTAT OPERATING AND WIRING REQUIREMENTS

The 6636 series air conditioner is designed to be operated from an RV Products electronic wall mounted thermostat. See component match-up sheet for thermostat part number and description. The thermostat is designed to operate 12 VDC controlled heating and air conditioning systems. The thermostat is designed to operate 12 VDC controlled heating and air conditioning systems. The thermostat must be operated from a 12 VDC power source.

The thermostat can control one stage heating and two stages of cooling. (The thermostat used to operate the 6636 series air conditioner must be capable of controlling two stage cooling systems.)

Maximum thermostat output for any load including the furnace control wire must not exceed one amp.

IMPORTANT

Current draws in excess of one amp or shorting any thermostat wires will cause permanent thermostat failure.

The installer must provide the power source used to operate both the thermostat and its control circuits. This power source must provide one amp of continuous current at 12 VDC.

The thermostat is pre-wired at RV Products with two quick connect electrical receptacles. There is one 9 pin receptacle carrying the 8 control wires required to operate the air conditioner, and a 3 pin receptacle carrying the two power supply leads and the one furnace control lead.

The thermostats 9 pin receptacle mates with a receptacle on one end of the RV Products 35' pre-wired thermostat harness. See component match-up sheet for harness part number and description.

The thermostat 3 pin receptacle has no mate in either the thermostat harness wiring or the thermostat package. Should the installer desire a total plug in system, then the mate for this connection will have to be purchased separately. Both the receptacle and the pins are manufactured by AMP (Aircraft Marine Products, Inc., Harrisburg, PA). In most cases the parts can be obtained through a local supply house.

The AMP part numbers are:

- 1) 3 pin male receptacle #7-480700-0
- 2) female pin (for male receptacle) #350218-1

Should the installer desire to hard wire this connection rather than purchasing the receptacle; the three pin connector can be cut from the wire ends, the wires stripped and spliced to complete the required connections. For further wire identification and function, reference Chart 2.

CHART 2

WIRE COLOR	FUNCTION (each wire connect with)
RED	+12 VDC Supply Lead
BLUE	-12 VDC Supply Lead
WHITE	Furnace Control Wire (engages furnace)

IMPORTANT

When using wire nuts to complete electrical connections, always apply a U.L. approved electricians tape and secure the wire nuts to the wires in a workmanlike manner.

THERMOSTAT HARNESS

RV Products produces a pre-wired 35' thermostat wiring harness for this system. See component match-up sheet for harness part number and description. This harness consists of the eight wires required for operating the air conditioner and quick connect receptacles for both the thermostat and the air conditioner connections.

At the thermostat, the connection is completed with a square 9 pin receptacle that slides together and snap-locks in place. When making this connection:

- 1) verify that the connectors are properly aligned
- 2) do not use excessive force when joining the connectors
- 3) verify that the connectors have snapped together on both sides.

The thermostat umbilical attaches to the unit with a rain-tight fitting. To install, remove the ring-nut from the rain-tight fitting and insert the wire end and fitting into the hole in the wirebox side. The ring-nut will now slide over the wire end and reinstall onto the rain-tight fitting threads. Tighten securely. The wire end plugs into the receptacle on the wirebox printed circuit board. Insure that the plug "snap-locks" into the receptacle.

Routing of the thermostat wiring harness must comply with all local and national electrical codes. Collect any excess thermostat harness in the air conditioner mounting compartment. Be sure to secure the excess wiring within the compartment. Coiling the excess harness into 3" diameter circles or larger is acceptable.

THERMOSTAT MOUNTING

Follow the instructions packed with the thermostat to select a location for thermostat mounting. Pay particular attention to choose a location which is not isolated from air currents and not subject to direct discharge from a cold air register.

Included in the thermostat installation instructions is a mounting template to aid in the installation.

IMPORTANT

To reduce the potential for thermostat failure: always connect the -12 VDC supply lead to the BLUE wire in the thermostat 3 pin receptacle before removing the "anti-static" protective covering. This will ensure that the thermostat circuitry is not damaged by static electricity during installation.

4. THERMOSTAT CHECKOUT

1. Before engaging power to any system, ensure the following:
 - A) All tools have been removed from the equipment.
 - B) All wiring is attached, routed and properly secured.
 - C) All panels (both mechanical and electrical) are in place.
 - D) The thermostat system switch is placed into the "OFF" position.
 - E) All co-workers have been warned that the equipment is being energized.
2. System wiring may be checked by referring to the wiring diagram located on either the back of the wiring box door or the back of the manual. The wiring diagram is a total system diagram including the wall thermostat and air conditioner. The wiring diagram is drawn so that all wiring box components are shown "positionally correct".

3. Before beginning the checkout procedure, thoroughly read the checkout instructions in either the thermostat installation instructions or in the owners manual provided with this product.

Keep in mind that the wall thermostat provides a 3 minute delay between off and on cycles. A 2.5 minute delay begins both as soon as the compressor cycles off, and as soon as the thermostat becomes energized. After completion of the 2.5 minute delay, an additional 30 second delay will begin as soon as the thermostat demands cooling.

There is also a 30 second delay between 1st and 2nd stage cooling. This is to prevent both compressors from starting simultaneously. To ensure that the thermostat calls for both 1st and 2nd stage cooling, verify that the cool setpoint is well below actual indoor temperature.
4. After complying with steps 1 through 3, engage power to all systems and begin checkout procedure.

5. UNIT DEPICTION FIGURES

PACKAGE AIR CONDITIONER MODEL NUMBER BREAKDOWN FOLLOWS:

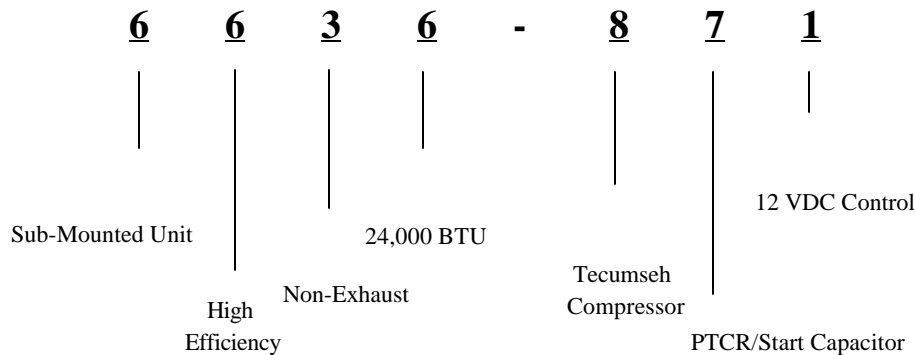

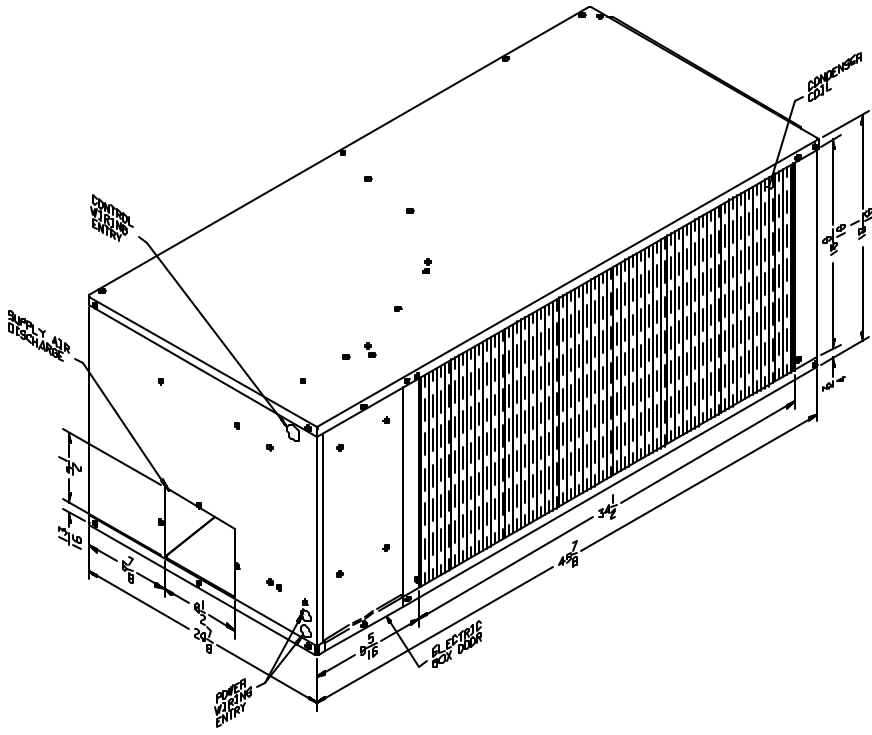

FIGURE 1

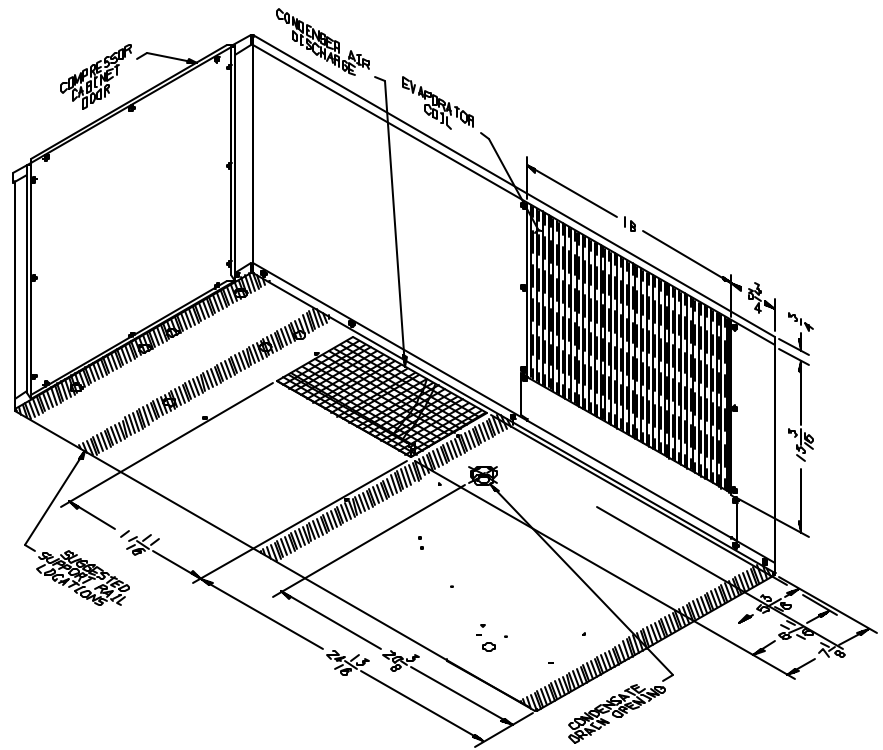
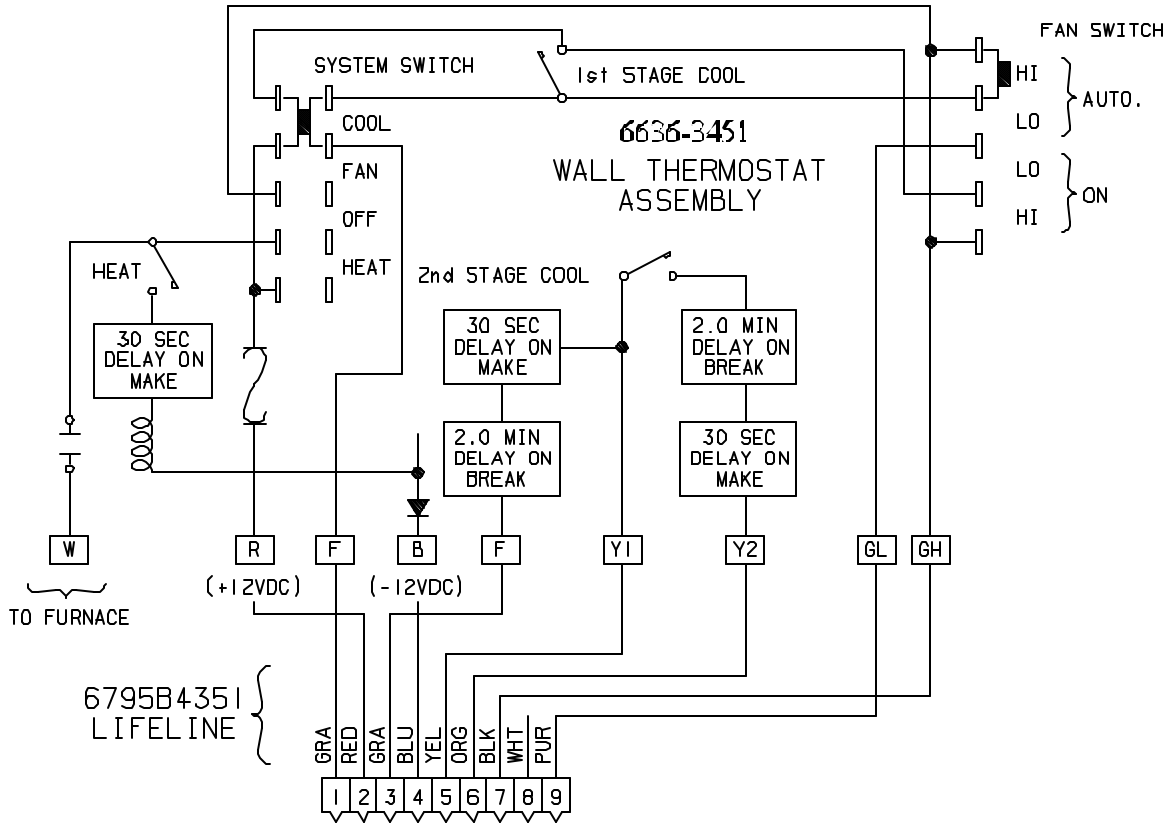

FIGURE 2

6. WIRING DIAGRAMS

Diagram 1976G119

Electronic Wall Thermostat Assembly (12 VDC)



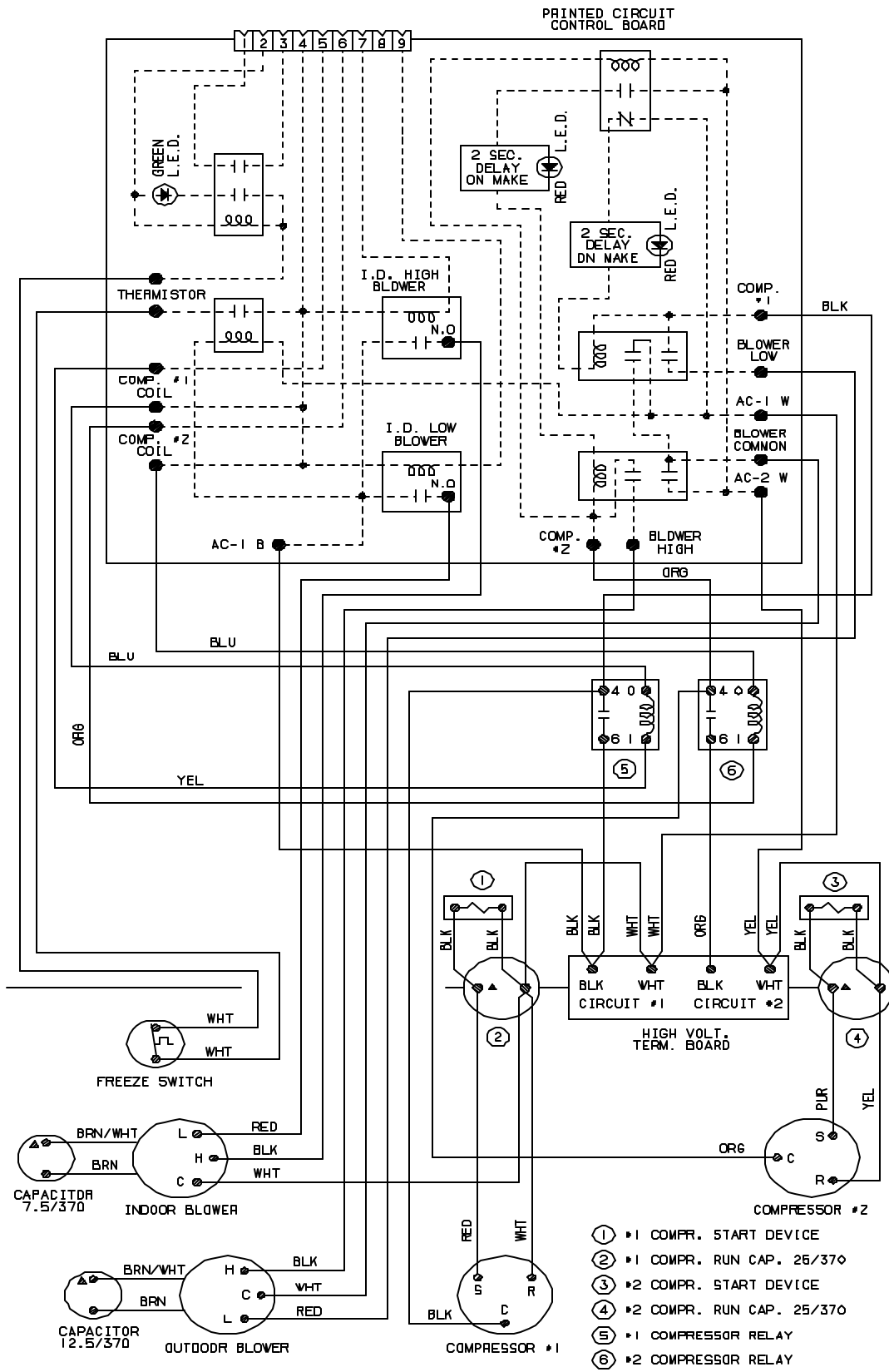

7. WIREBOX COMPONENT CHECKOUT

FIGURE 13

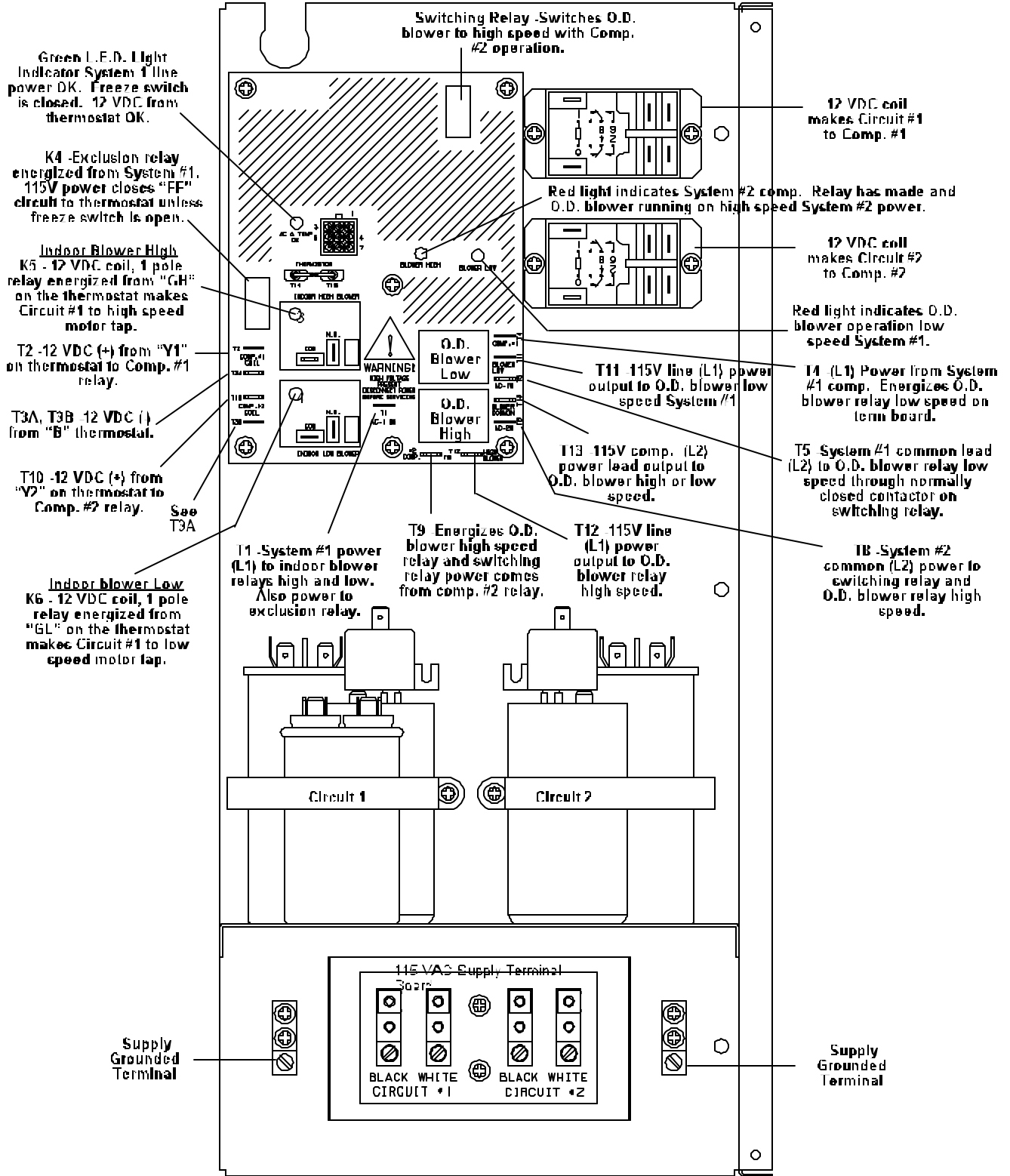

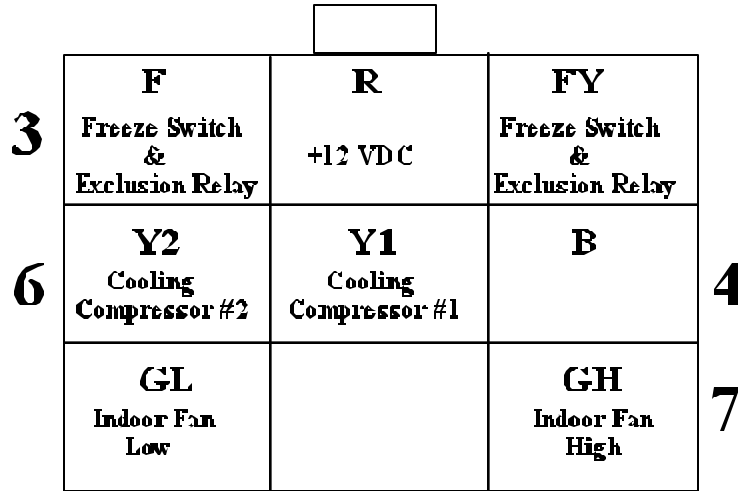

FIGURE 14

Plug positions on the p.c. board. If no voltage is detected at the p.c. board connector, check for voltage at the thermostat.

All functions of this air conditioning unit are subject to thermostat time delays according to the operation manual.

8. INDOOR BLOWER MOTOR REMOVAL

- | | |
|--|---|
| <ol style="list-style-type: none"> 1. Remove indoor blower access panel. 2. Disconnect wiring from motor terminal block and capacitor. 3. Remove 4 screws from venturi (See #1, Figure 7). 4. Remove 3 screws from motor mount bracket (See #2, Figure 7). | <ol style="list-style-type: none"> 5. Remove motor assembly from scroll. 6. Remove blower wheel and motor mounting bracket. <p>Note: Upon reassembly, the references made on Figures 7 and 8 shall be used for proper reassembly.</p> |
|--|---|

SIDE VIEW

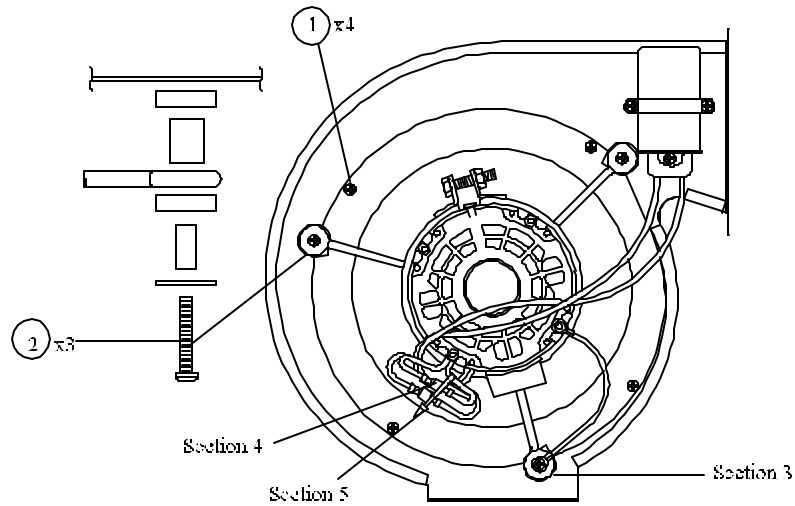

FIGURE 7

- Section 1. Position motor with terminal block parallel to motor mount clamp. Assemble motor mount into scroll in orientation shown.
- Section 2. Torque nut to 65 in. lbs. min.
- Section 3. Ground wire terminal assemblies between screw head and washer.

- Section 4. Motor rotation wires to be connected: Yellow to Yellow and Orange to Orange.
- Section 5. Bundle the rotation and capacitor wires up and wire tie together.

END VIEW

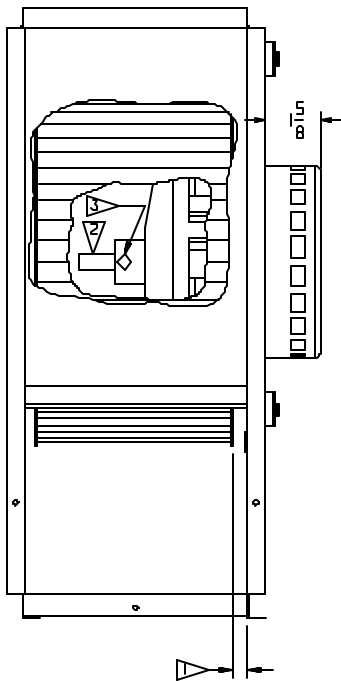

FIGURE 8

1. Wheel must be mounted with a minimum of 5/16" clearance to scroll sides.
2. Apply grease to motor shaft before assembling wheel.
3. Torque set screw on flat of shaft to 110 #10 in. lbs.

9. OUTDOOR BLOWER MOTOR REMOVAL

1. It will be necessary to remove the top panel of the unit.
 2. Remove 4 screws that attach scroll housing to side panel (See #1, Figure 9).
 3. Disconnect wiring from motor terminal block.
 4. Remove scroll/motor assembly from the unit.
 5. If at this point only the blower wheel needs replaced, then remove 4 screws from inboard venturi. Remove and replace blower wheel (see note) or else go to Step 6.
 6. Disconnect wiring at capacitor.
 7. Remove 4 screws from venturi (See #1, Figure 10).
 8. Remove 4 screws from motor mount bracket (See #2, Figure 10).
 9. Remove motor assembly from scroll.
 10. Remove blower wheel and motor mounting bracket.
- Note: Upon reassembly, the references made on Figures 9 and 10 shall be used for proper reassembly.

BOTTOM VIEW

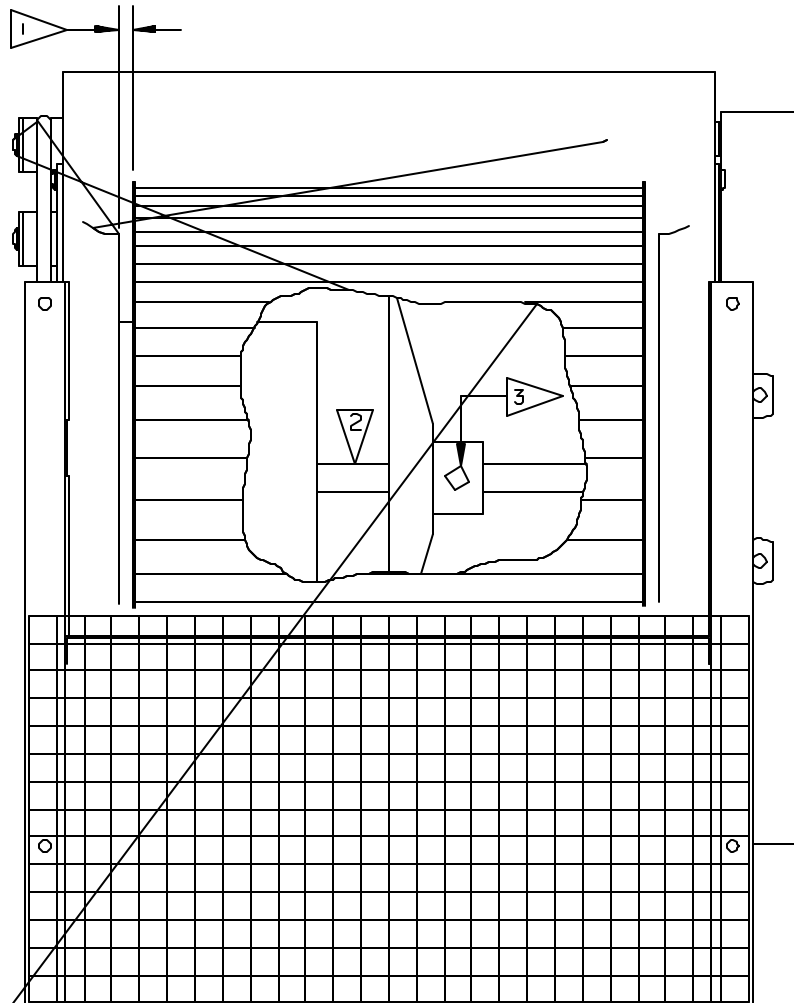

FIGURE 9

1. Wheel must be mounted with a minimum of 1/4" clearance to both venturis.
2. Apply grease to motor shaft before assembling wheel.
3. Torque set screw on flat of shaft to 110 #10 in. lbs.

10. CAP TUBE REPLACEMENT

1. Remove top panel.
2. Remove panels from end and side covering compressors and outdoor blower wheel.
3. Remove outdoor blower and housing.
 1. Make sure to label the wires of the fan motor when you take them off.
4. Be certain at this point that the refrigerant charge has been removed from the system/systems being serviced.
5. Unbraid cap tube assembly/assemblies from points (See #1 and #2, Figure 12). Make note of plumbing and cap tube locations (the replacement tubes will have to go back to the same locations).
6. Cut wire ties holding cap tube assemblies to other plumbing and remove assembly.

Note: Upon reassembly, the references made on Figures 11 and 12 shall be used for proper reassembly. The assemblies shall be secured with wire ties in order to prevent excess chafing and vibration.

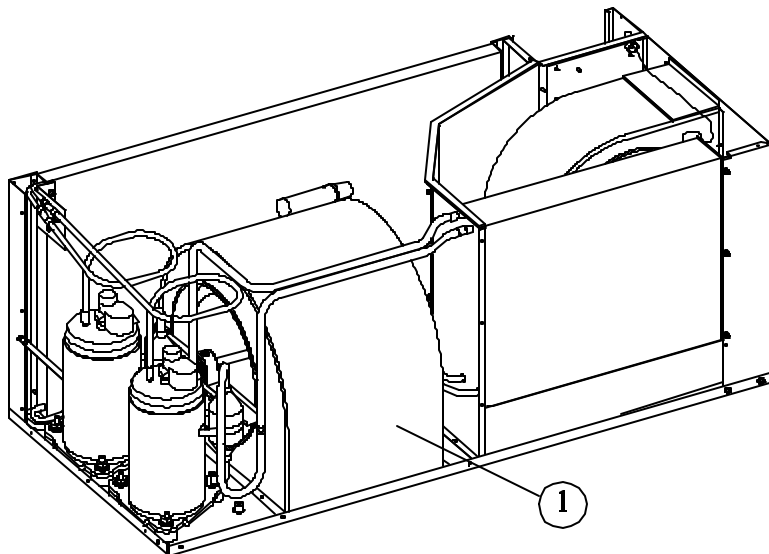

FIGURE 11

11. EVAPORATOR COIL REPLACEMENT

1. Remove top and side panels next to evaporator.
2. Remove refrigerant charge from both systems.
3. Unbraid joints #1 and #3, Figure 12.
4. Remove freeze sensor in evaporator coil.
5. Remove screws (#4, #5, #6, Figure 12).
6. Upon reassembly, the references made on Figure 12 shall be used for proper reassembly.

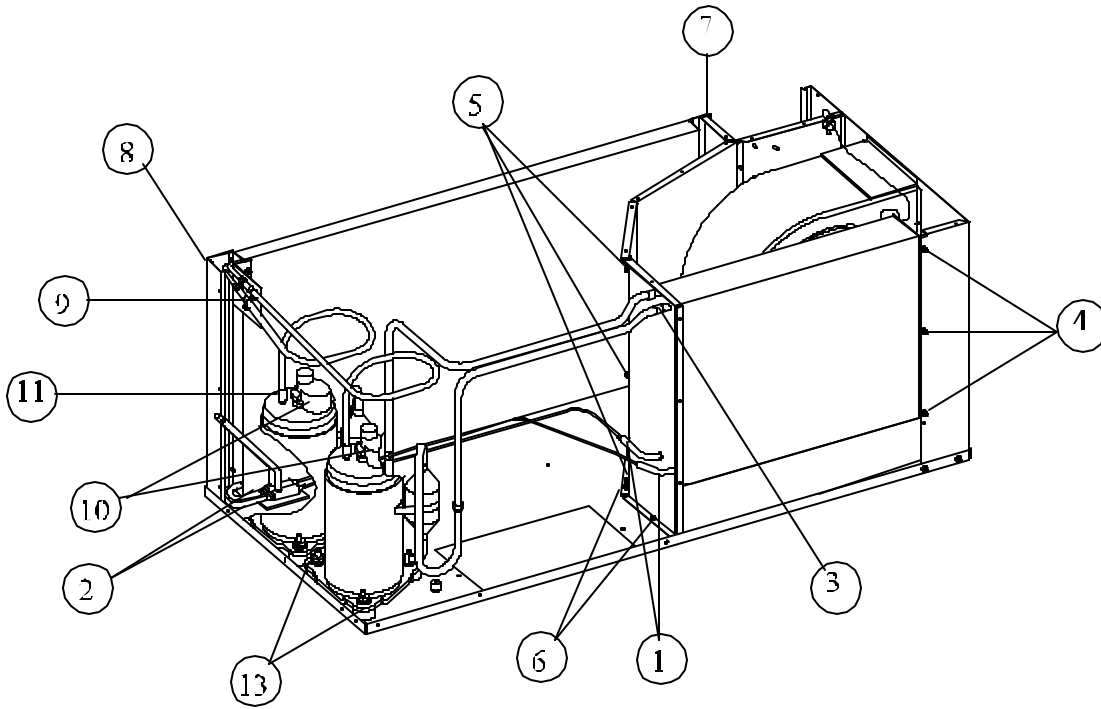

FIGURE 12

12. CONDENSER COIL REPLACEMENT

1. Remove top panel.
2. Remove screws along wirebox side of coil (See #7, Figure 12).
3. Remove corner panel (See Figure 12).
4. Be certain at this point that the refrigerant charge has been removed from the systems.
5. Make note of plumbing locations. The plumbing will have to go back to the same locations on the new coil.
6. Unbrazed discharge and liquid lines at points #2 and #9, Figure 12.
7. Remove condenser coil.

13. COMPRESSOR REPLACEMENT

1. Remove compressor access panel.
 2. The top panel may be removed at this point if it allows technicians better access to perform service.
 3. Remove refrigerant charge from system/systems being serviced.
 4. Remove terminal caps (See #10, Figure 12).
 5. Remove wiring from compressor terminal block (cut wire ties on suction line).
 6. Unbrazed plumbing at points #11 and #12, Figure 12 (protect any wiring and insulation from torch flame).
 7. Remove mounting nuts and washers (See #13, Figure 12).
 8. Remove compressor from unit.
- Note: Upon reassembly, compressor wires shall be wire tied to suction lines to prevent excess chafing.

14. ELECTRICAL FLOW CHARTS

6636 SERIES OPERATION SEQUENCE

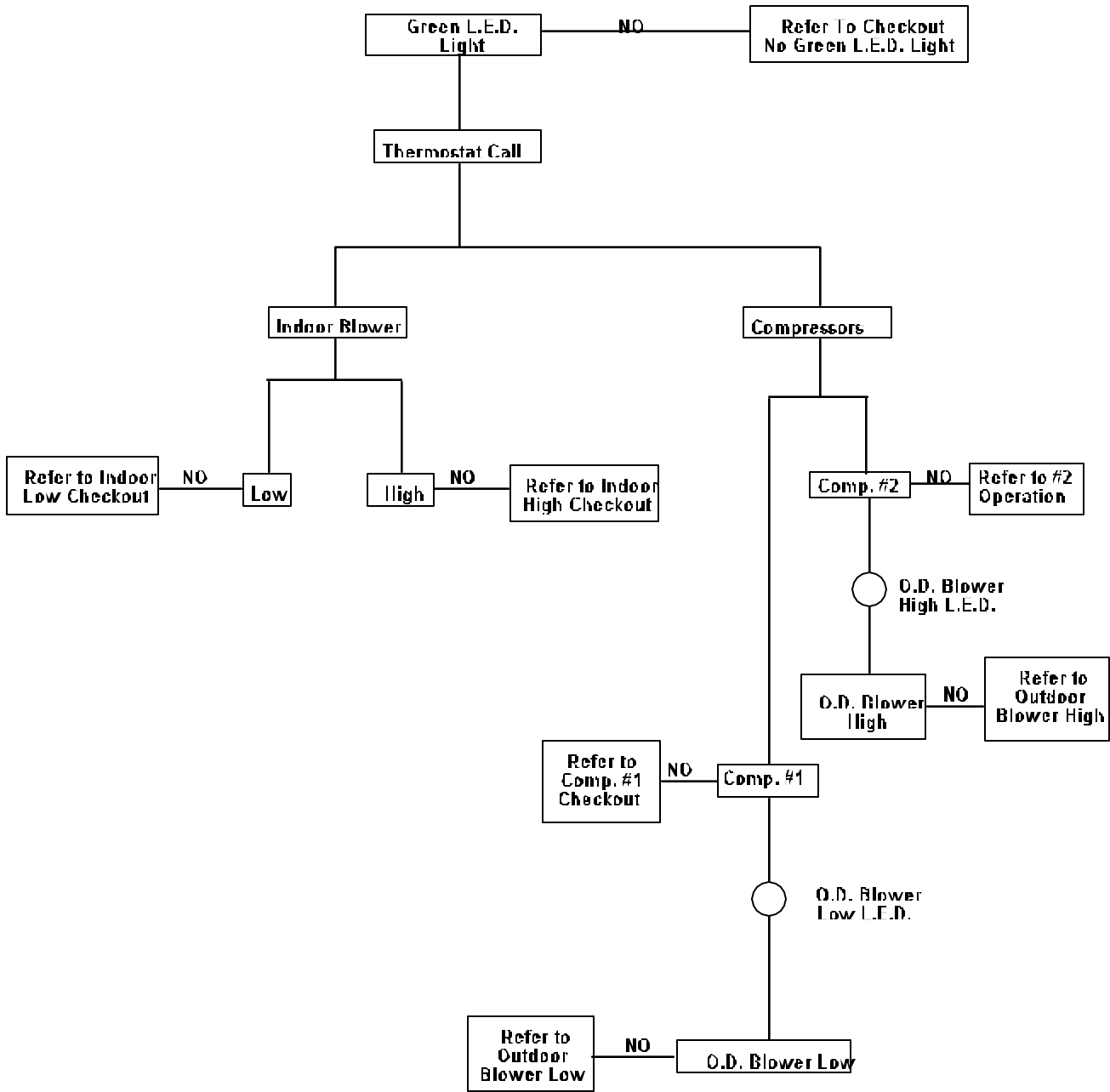

**CHECKOUT/NO GREEN L.E.D. LIGHT
FY/F CIRCUIT TO THE THERMOSTAT**

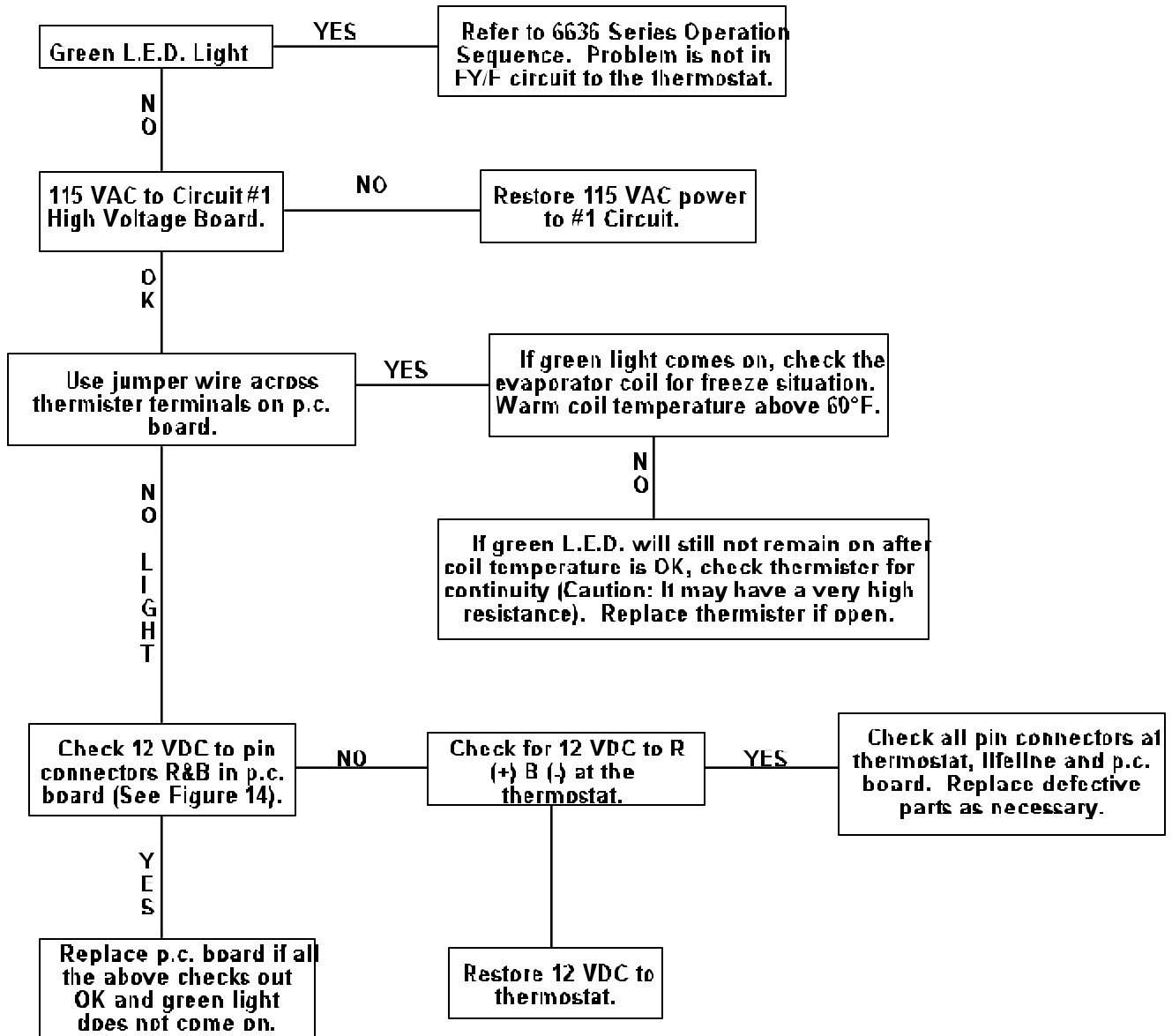

I.D. BLOWER LOW SPEED THERMOSTAT ON LOW FAN

Note: All operating functions subject to thermostat time delays.

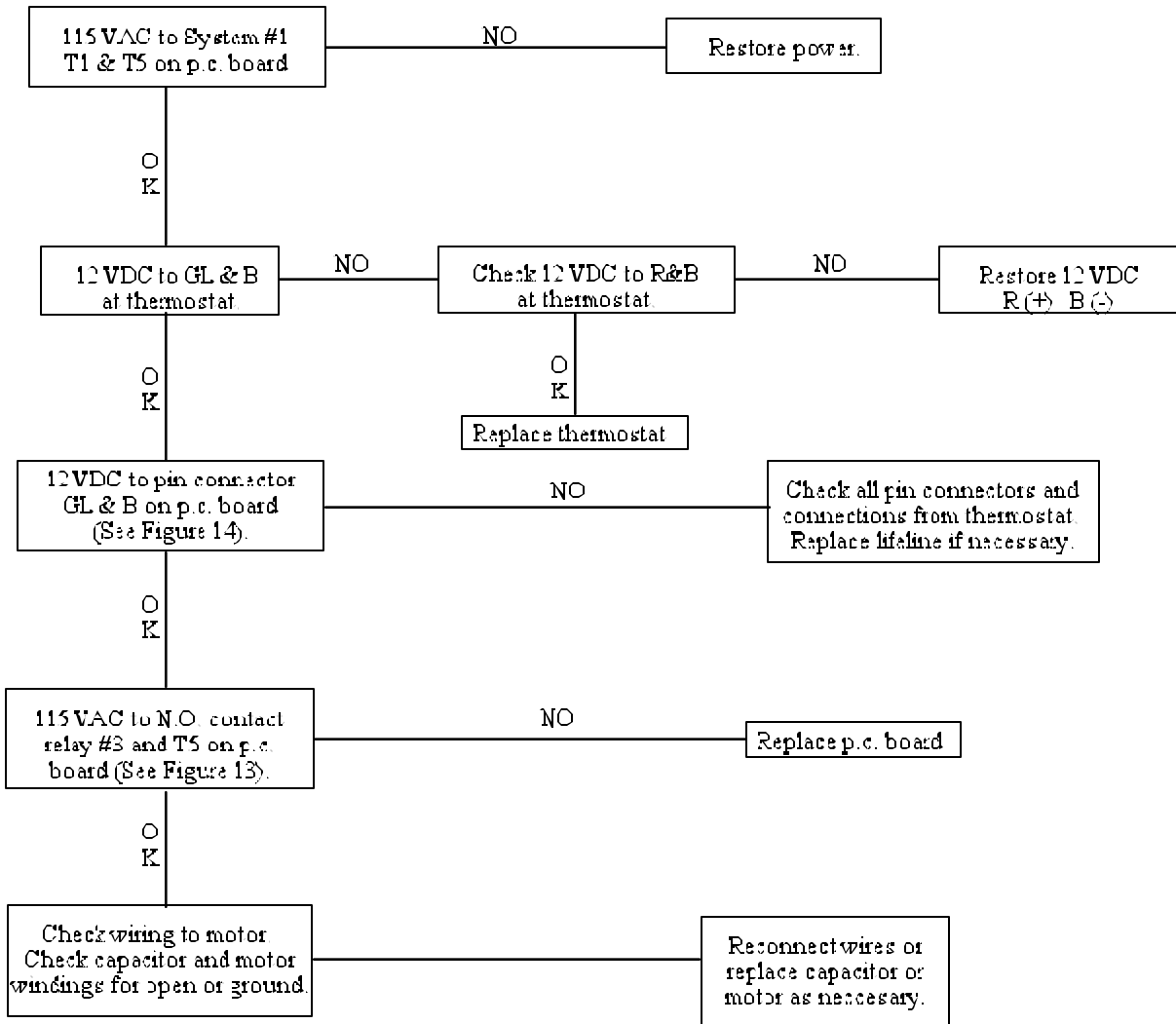

I.D. BLOWER HIGH SPEED THERMOSTAT ON HIGH FAN

Note: All operating functions subject to thermostat time delays.

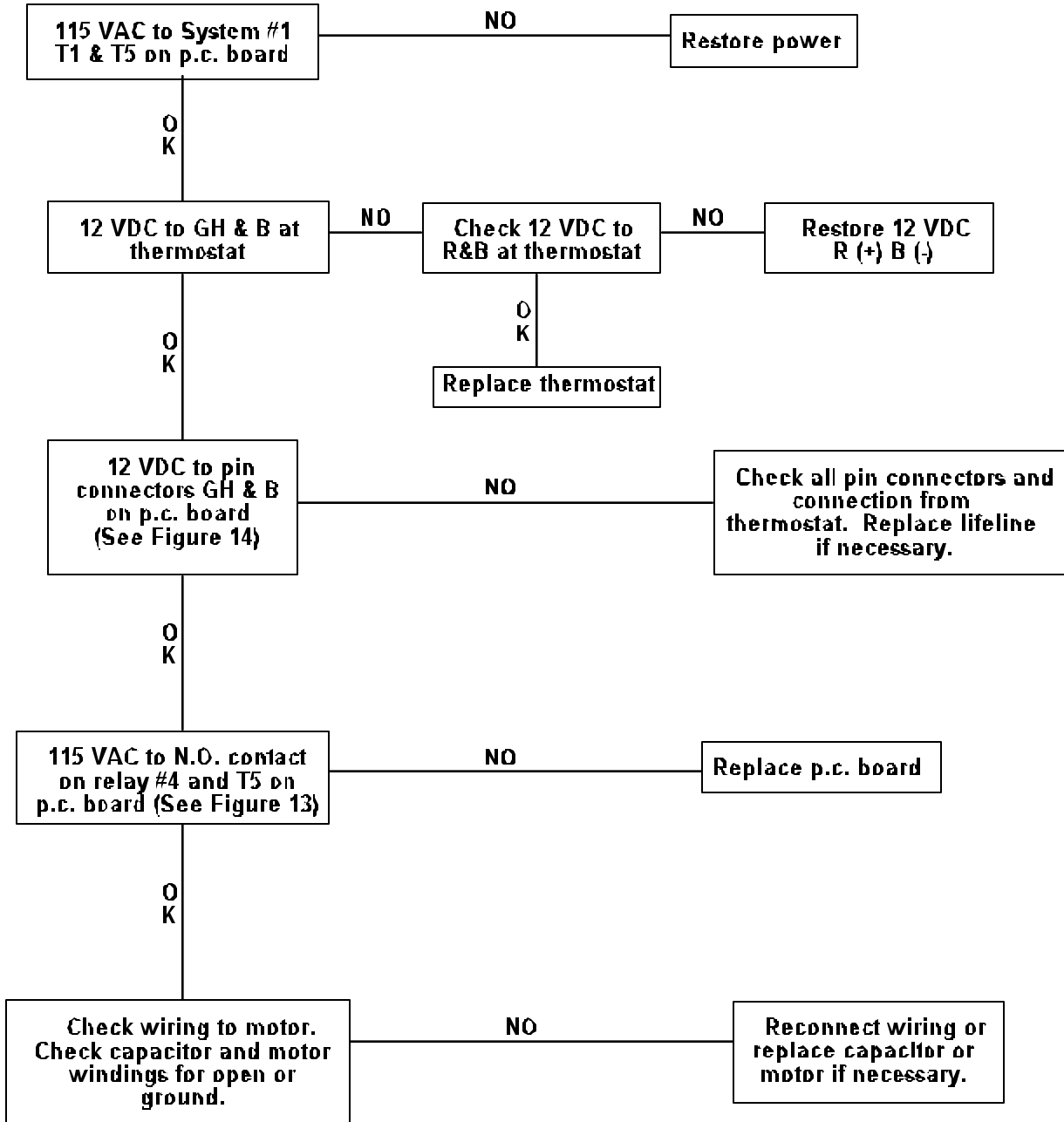

COMPRESSOR #1 CHECKOUT THERMOSTAT CALLING FOR COMPRESSOR

Note: All operating functions subject to thermostat time delays.

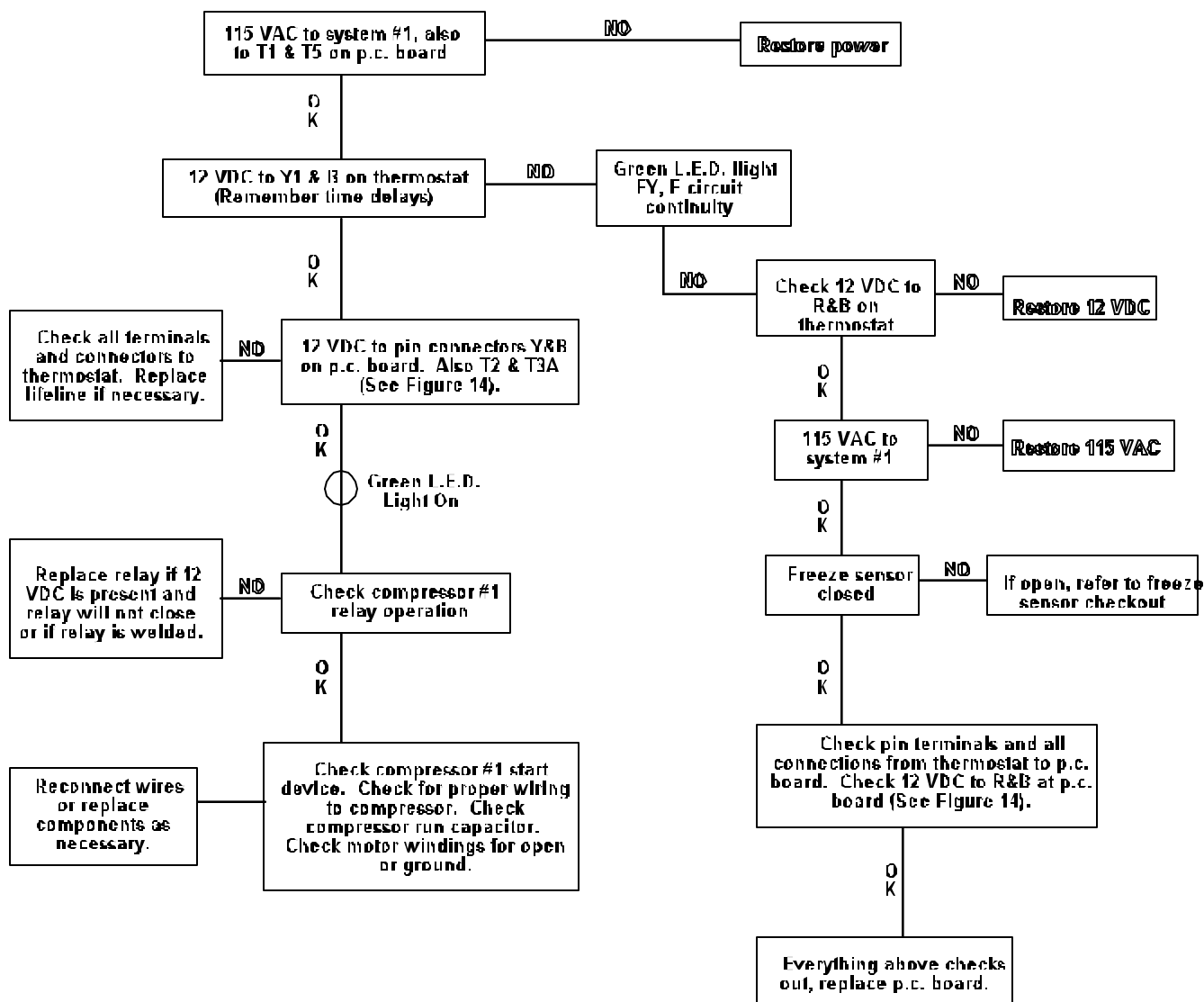

COMPRESSOR #2 CHECKOUT THERMOSTAT CALLING STAGE 2 COOLING ONLY

Note: All Operating Functions Subject To Thermostat Time Delays

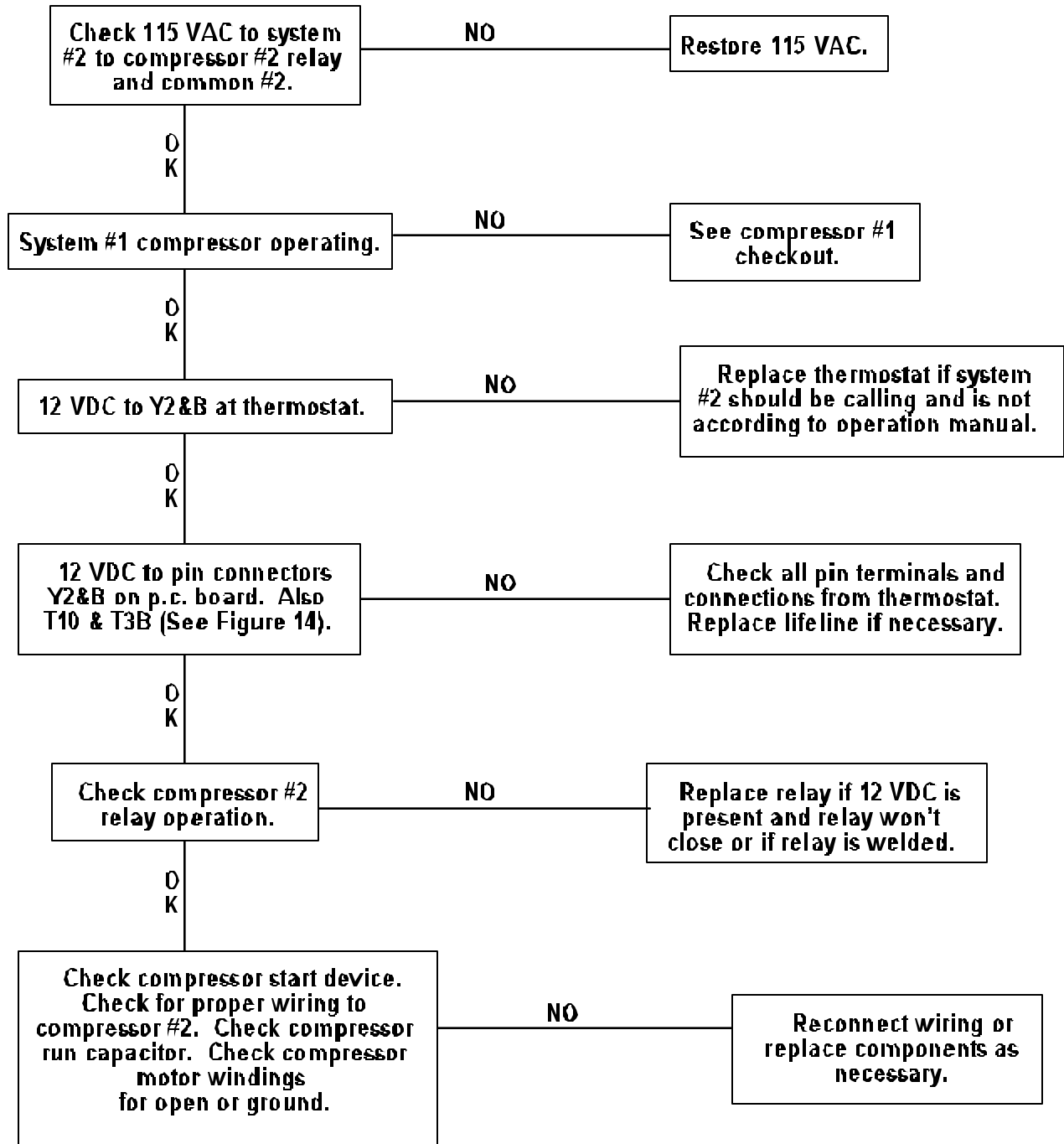

**CHECKOUT OUTDOOR BLOWER
LOW SPEED**

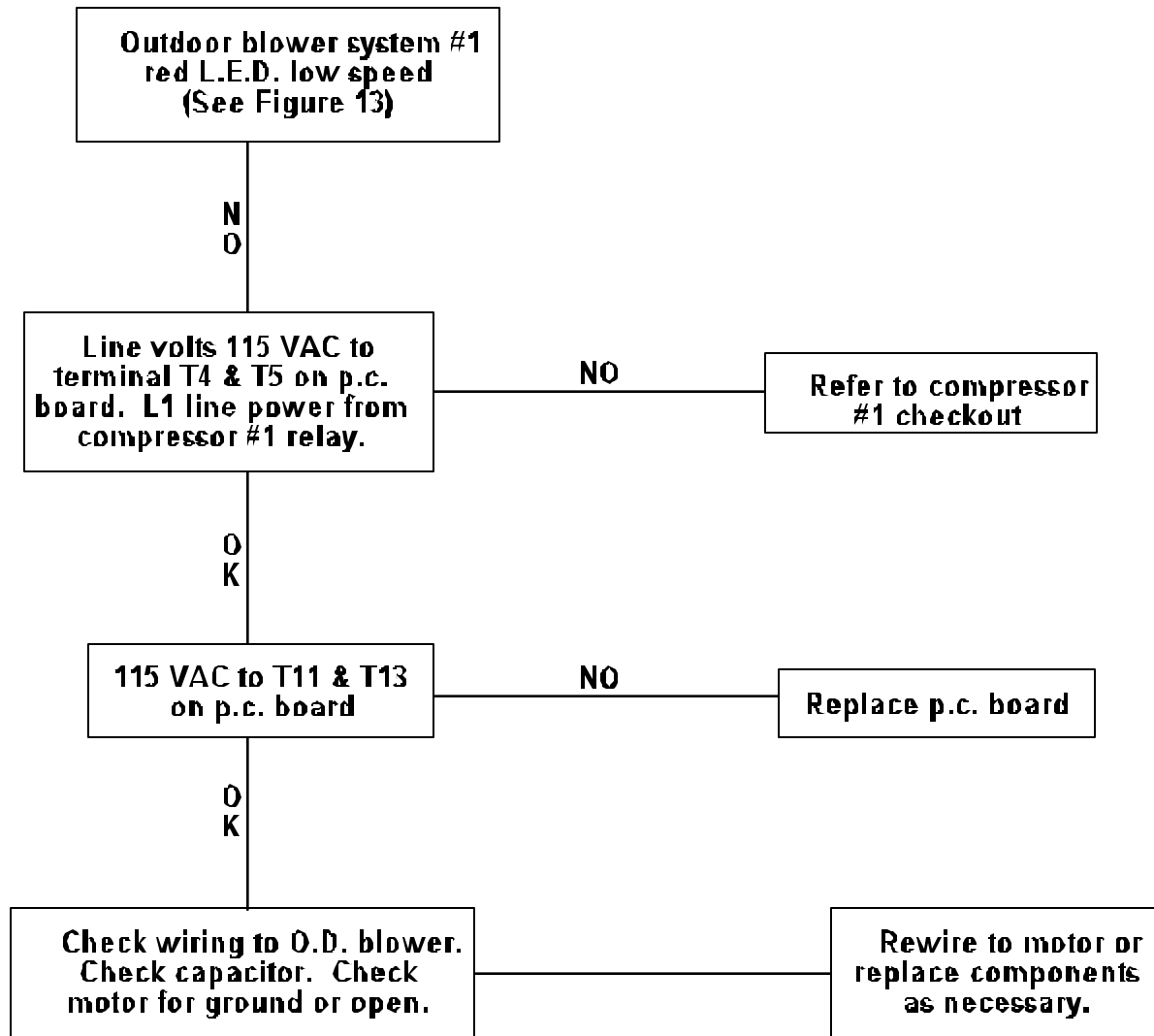

CHECKOUT OUTDOOR BLOWER HIGH SPEED

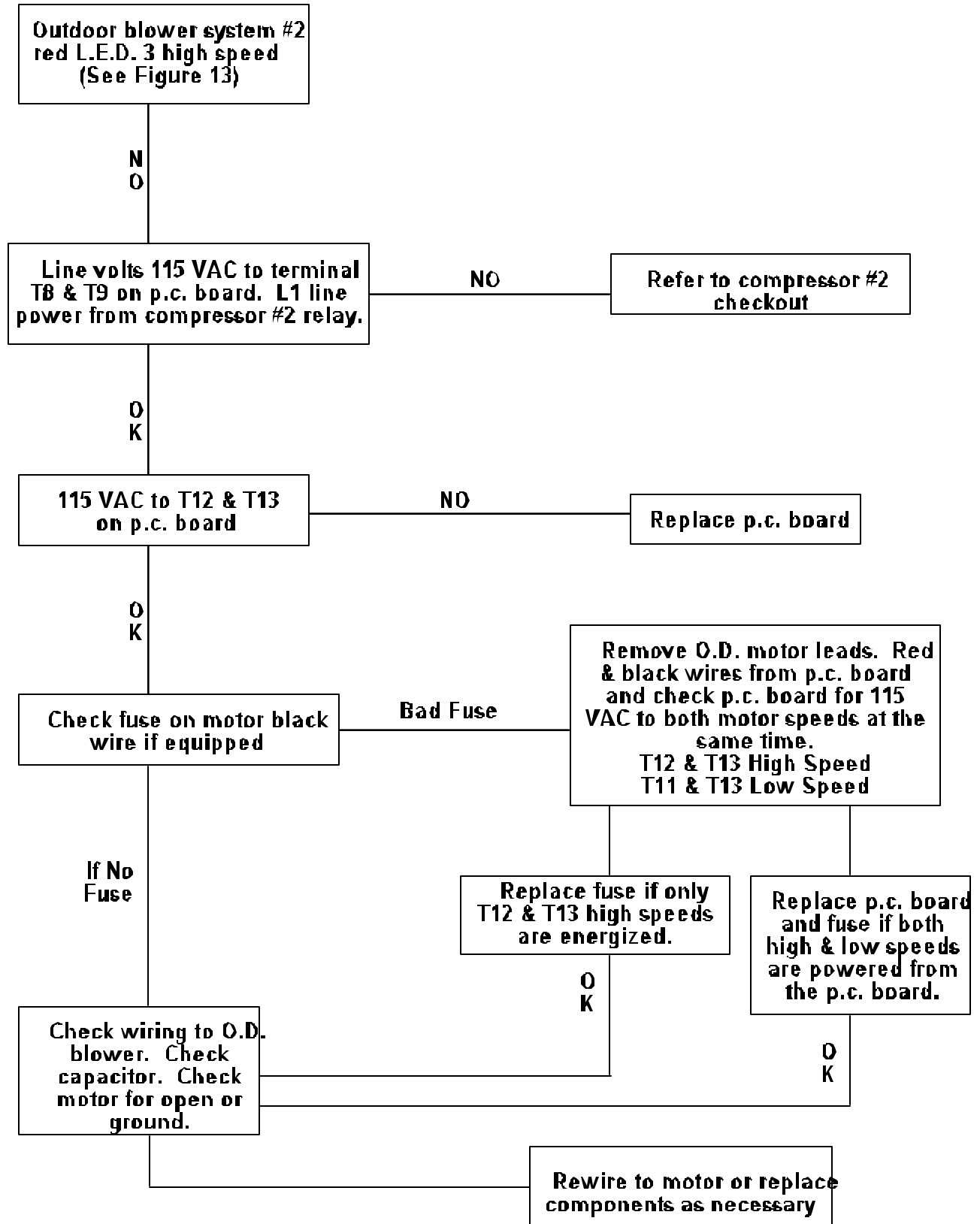



RV Products
A Division of Airxcel, Inc.
P.O. Box 4020
Wichita, KS 67204