



INSTALLATION INSTRUCTIONS

FOR

8330*735* Heat Ready A/C

8530*733* Heat Pump

8530*735* Heat Pump

FLUSH MOUNT CEILING PLENUM

Airxcel, Inc.
RV Products Division
P.O. Box 4020
Wichita, KS 67204

TABLE OF CONTENTS

Warnings	2
Package Contents	2
General Information	3
Ceiling Plenum Installation Requirements	3
Supply Ducting and Registers	4
Routing Thermostat Wiring	5
Routing High Voltage A/C Wiring	6
Ceiling Plenum Mounting	6
Installing the Control Box and Heater Assembly	6

WARNINGS

IMPORTANT NOTICE

These instructions are for the use of qualified individuals specially trained and experienced in installation of this type equipment and related system components.

Installation and service personnel are required by some states to be licensed. **PERSONS NOT QUALIFIED SHALL NOT SERVICE THIS EQUIPMENT.**

WARNING

Improper installation may damage equipment, can create a hazard and will void the warranty.

The use of components not tested in combination with these units will void the warranty, may make the equipment in violation of state codes, may create a hazard and may ruin the equipment.

WARNING – SHOCK HAZARD

To prevent the possibility of severe personal injury or equipment damage due to electrical shock, always be sure the electrical power to the appliance is disconnected during installation.

CAREFULLY FOLLOW ALL INSTRUCTIONS AND WARNINGS IN THIS BOOKLET TO AVOID DAMAGE TO THE EQUIPMENT, PERSONAL INJURY OR FIRE.

NOTE

The words “Shall” or “Must” indicate a requirement which is essential to satisfactory and safe product performance.

The words “Should” or “May” indicate a recommendation which is not essential and not required but which may be useful or helpful.

PACKAGE CONTENTS

- 1) Wirebox Assembly
- 1) Duct Divider Board (not provided with 7332 model, ordered separately)
- 1) Insulated Duct Plate
- 1) Return Air Grille
- 1) Return Air Filter
- 1) Mount Frame

- 1) Small Parts Package Consisting of:

- 4) Bolts
- 7) Screws
- 1) Strain Relief
- 2) Wing Nuts

Some packages may contain:

- 3) Wire Nuts
- 1) Evaporator Freeze Sensor
- 4) Washers
- 4) Springs

GENERAL INFORMATION

The flush mount ceiling plenum is designed for application in systems that utilize field fabricated (OEM supplied) cold air ducting. The ducting must be routed through the ceiling cavity (between the interior ceiling and roof). Ducting specifications are given in the section labeled "Supply Ducting and Registers".

This system utilizes a single, non-ducted centrally located return air opening. The return air opening is contained within the ceiling plenum. The ceiling plenum must be located directly below the roof opening used for mounting the roof top unit.

All manual controls have been removed from the ceiling plenum. They have been replaced with control relays. The relays are mounted in the electrical box of the ceiling plenum. The relays contain 12 VDC coils (which are energized by a wall mounted thermostat), with contacts that control the high voltage used to power the roof top unit.

All air conditioning functions are controlled by the low voltage wall mounted thermostat. The thermostat controls a 12 VDC electrical circuit which is used to energize the relays in the ceiling plenum. The thermostats that Airxcel, Inc. provides for the system are combination (Heat/Cool) thermostats. These thermostats are capable of operating both the roof top air conditioner and any furnace with a 12 VDC control circuit of 1 amp or less (continuous current).

All air conditioning equipment is subject to freeze up when evaporator air flow is sufficiently reduced. Ducting of any length creates potential for reduced evaporator air flow and system freeze-up. To protect both the installer and Airxcel, Inc. from conditions that promote reduced air flow and system freeze-up, Airxcel, Inc. has equipped the ceiling plenum

compressor control circuit with a low temperature probe. The low temperature probe monitors the temperature of the air conditioner evaporator coil. When the temperature of the evaporator coil drops below 28 degrees F, the switch will open, stopping compressor operation. Compressor operation will resume once the evaporator warms to 55 degrees F.

IMPORTANT

The low temperature sensor is part of the ceiling plenum electrical circuit. The probe must be inserted into the evaporator coil of the roof top unit by the installer when bolting the ceiling plenum to the roof top unit.

The 8330*735* ceiling assembly mates with any roof top air conditioner to provide optional electric heat as well as cooling.

The 8530*733* and 8530*735* ceiling assemblies mate with any roof top heat pump.

The ceiling plenum comes equipped with the following:

- 1) all hardware required for mounting and securing the roof top unit including a return air heater
- 2) a means of attaching the field fabricated ducting
- 3) the return air grille and filter

CEILING PLENUM INSTALLATION REQUIREMENT

1. The ceiling plenum must be installed under the roof opening.

The ceiling plenum bolts below the roof top unit. Compression of the framed ceiling cavity between the roof top unit and the ceiling plenum is what holds both components in place.
2. Ceiling cavity depth (the measurement from the ceiling to the roof – maximum 6").
3. The high voltage service for the roof top unit must be routed into the ceiling plenum. To prevent wire pinching and to promote ease of installation, allowances must be made for routing the high voltage supply wiring into the front of the roof opening.
4. Thermostat wiring must be run from the wall thermostat mounting location to the wirebox low voltage terminals. To prevent wire pinching and to promote ease of installation, allowances must be made for routing the low voltage wiring into the front of the opening.
5. The wirebox has a 9 pin socket extending from the front. This mates with the roof top unit high voltage electrical conduit. When making this connection, verify that the plugs are properly aligned and have snapped together secured.
6. The wirebox also has a two pin receptacle which mates with the umbilical plug from the heater assembly.

7. A low voltage terminal strip on the front of the box connects to the thermostat wires. The wires connect by 1/4" quick connects.

8. Provided with the ceiling plenum is a divider board which is used to separate the warm return air from the cold supply air.

Plenum Terminal Designation	Thermostat Wire Connection	Function Of Low Voltage Terminal Extending From Ceiling Plenum
B	BLUE	Completes -12 VDC circuit for all relays
Y	YELLOW	Energizes coil on Compressor Relay
GH	GREEN	Energizes coil on High Fan Relay
GL	GRAY	Energizes coil on Low Fan Relay
W	WHITE	Energizes coil on Heat Relay
FREEZE (F)	WHITE	Evaporator freeze sensor connections
FREEZE (F)		

SUPPLY DUCTING AND REGISTERS

A. Ducting

1. The field fabricated supply ducting must attach to both sides of the ceiling plenum. A minimum of two ducts are required, with one duct attached to each side of the plenum (See Figure 1).
2. Each duct must have a minimum height of 1 1/2", maximum height cannot exceed 4 inches. Total free area inside each duct must be no less than 10 square inches.

NOTE

To decrease restriction and increase air flow, the ducting should make as few bends and turns as possible. When corners or turns are required, we recommend that you radius the corners to keep air flow to a maximum.

Ten (10) square inches of free area per duct is the minimum requirement, larger ducting will improve air flow and system performance.

3. Where ducting secures to the ceiling plenum, maximum width is 8 inches.
4. All field fabricated cold air supply ducting must be insulated and must have a vapor barrier.

IMPORTANT

Insulating reduces cooling loss and helps prevent water staining of the vehicle ceiling due to moisture condensation.

B. Registers

Supply (cold air) registers should have a minimum discharge area of 48 square inches per system, or 24 square inches per duct.

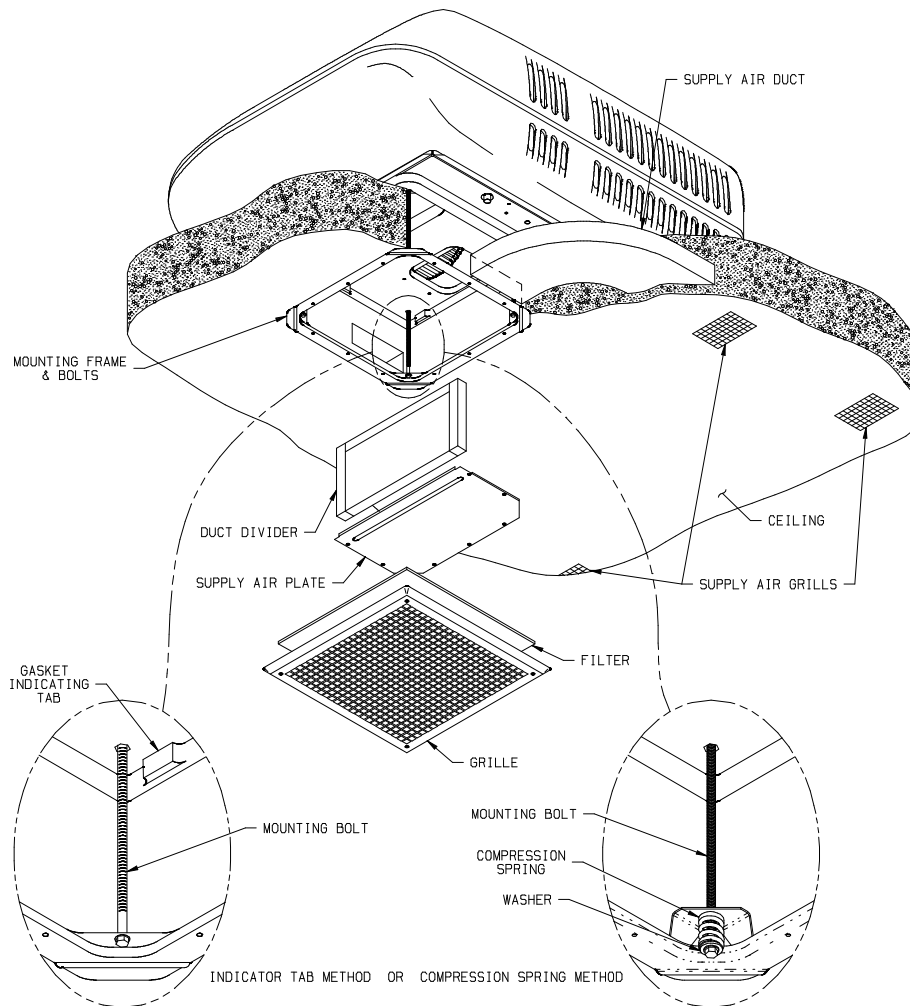

FIGURE 1

ROUTING THERMOSTAT WIRING

1. Following the instructions packed with the thermostat, determine a location for thermostat mounting.
2. Following Airxcel, Inc. low voltage wiring specifications and all local and national electrical codes:
 - A. Route the thermostat 12 VDC supply wiring from the power source to the thermostat mounting location.
Two wires are required:
One supply lead must be +12 VDC and red in color.
The second supply lead must be -12 VDC and blue in color.
 - B. To protect the wall mount thermostat from over-current damage, a 2 amp fuse has been provided with the thermostat.
 - C. Route the thermostat control wiring from the thermostat mounting location into the front of the ceiling plenum opening.
Five (5) wires are required. These wires are as follows:
 - (1) Blue wire for -12 VDC circuit
 - (1) Yellow wire for compressor circuit
 - (1) Green wire for high fan circuit
 - (1) Gray wire for low fan circuit
 - (1) White wire for heat operation

3. Airxcel, Inc. low voltage wiring specifications:
 - A. All low voltage wiring should be no smaller than 18 gauge.
 - B. Low voltage wiring must be routed into the front side of the ceiling plenum opening.

ROUTING HIGH VOLTAGE A/C WIRING

Following Airxcel, Inc. high voltage wiring specifications and all local and national electrical codes, route the roof top unit 115 VAC supply wiring from its power source to the wirebox.

High Voltage Wiring Specifications based on Minimum Overcurrent Protection Device Amperage – (see upper unit nameplate)

1. U.L. requires copper conductors only with minimum #12 AWG when using the minimum recommended overcurrent protection device. Higher rated devices or longer wiring runs will require #10 AWG or greater copper conductors.
2. To prevent voltage drops greater than 10% during starting loads, adhere to the following guideline:

For lengths greater than 50', use #10 AWG or larger copper conductors. Match to the overcurrent protection device provided.

Circuit Protection – Refer to upper unit nameplate.

High Voltage Wiring Specifications based on Overcurrent Protection Device rated higher than the minimum required (see upper unit nameplate)

Follow all local and NEC (National Electrical Code) for proper sizing of wire AWG based on Overcurrent Protection Device selected and the length of the wiring run to the air conditioner.

CEILING PLENUM MOUNTING

Mounting (Refer to Figure 1)

1. Place the roof top unit over the roof opening.
2. Position the mount frame into the ceiling opening (See Figure 1).

3. Using the four bolts provided, secure the mount frame to the roof top unit. The four mounting bolts are to be applied up through the bottom of the mount frame and into the bottom of the roof top unit. Some models include compression springs that should be tightened just until springs achieve closure (See Figure 1).

INSTALLING THE CONTROL BOX AND HEATER ASSEMBLY

All control boxes install by one of two methods.

1. Remove the control box assembly cover which is held by two sheet metal screws. Feed the field lead wires and ground through the strain relief found with the control box.
2. Connect supply conductors to control box. Some models will terminate to lugs on the p.c. board marked "Black", "White" and "GND". Some models will terminate to "pigtail" leads with provided wire nuts. Black to black, white to white and ground to green.
3. Insure that no bare wires can come into contact with live electrical parts and that wires cannot be pinched between the control box sides and lid. Insert the strain relief into the control box entry hole to secure the field wiring. Reinstall the control box lid.

Refer to Figure 1

1. Measure the distance between the ceiling and the upper unit basepan, add 1/2" to this measurement and using this calculated value, cut the duct divider assembly board to this height. **ALWAYS CUT OFF THE BOTTOM EDGE (THE EDGE WHICH IS NOT PROVIDED WITH A FOAM STRIP).**
2. Carefully wedge this divider between the walls of the roof opening and up against the upper unit basepan. The upper unit mount gasket has a locator block on each side which locates the divider board.
3. Attach the insulated duct plate to the mount frame using the screws found in the small parts package.

The optional add-on heater assembly may now be installed on heat ready A/C and Heat Pump models. The 47000 series units use the 47233*4551 heat kit. The 48000 and 49000 series units will use the 9233*4551 heat kit.

For 48000 or 49000 series units, position the heater assembly into the return air opening as shown in Figure 2. Insure that the set screw is retracted sufficiently to allow installation over the basepan extrusion.

The heater bracket **must be installed between the basepan and the plastic drain pan** (See Figure 3).

Tighten set screw to secure the assembly so as to prevent movement.

For 47000 series units, install as shown in Figures 4 and 5.

Insert the two-pin connector of the heater umbilical into the receptacle on the control box. Insure that the connector snap-locks into position.

TIE ALL WIRING TO INSURE NO CONTACT WITH THE HEATER OR ANY SHARP EDGES. KEEP IN MIND THAT HIGH VELOCITY AIR WILL BE ENCOUNTERED IN THIS AREA.

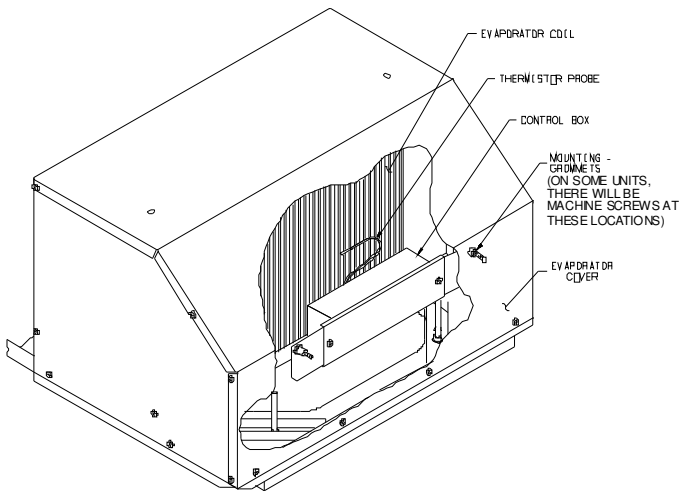
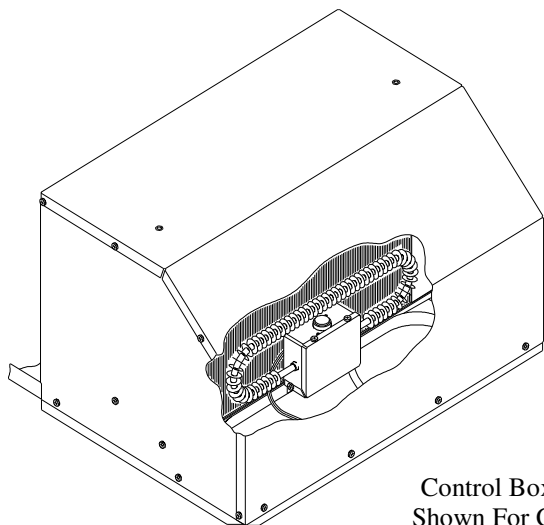

FIGURE 2



Control Box Not Shown For Clarity

Attach the thermostat wires to the control box per illustration below:

Control Box 8330*735* and 8530*735*

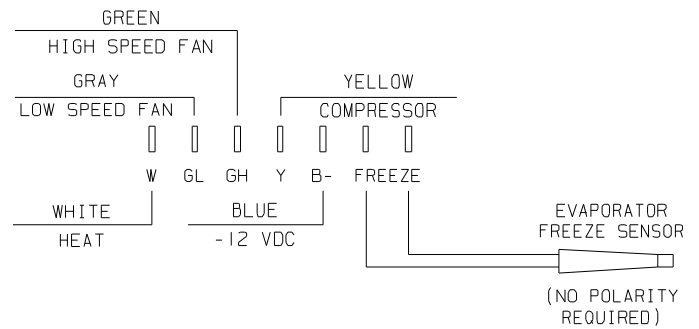

Control Box 8530*733*

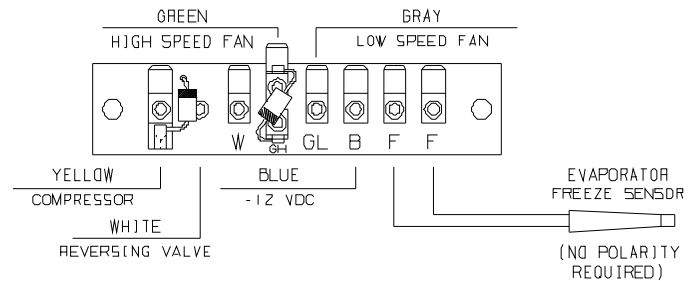

Mount control box inside upper unit evaporator cover. Position the control box over the existing screws and secure with two wing nuts provided. Note that on the 47000 series units, the control box installs with the wires exiting upward.

Insert the evaporator freeze sensor between evaporator fins near the bottom center of the evaporator and between the bottom two tubes (See Figure 3). Insert straight in until contacting the staggered tube directly in back of the insertion point. When contact has been made, elevate the exposed end of the sensor approximately 45 degrees, then continue insertion at a 45 degree angle until the sensor is completely embedded into the evaporator.

Gently fold all wiring into the electrical box while verifying that it is not either pinched or cut.

Complying with the warnings listed below, connect the high voltage supply wiring to its power source. Be sure all power remains off until beginning checkout procedure.

DANGER

TO PREVENT THE POSSIBILITY OF SHOCK INJURY FROM APPLIANCE OPERATION:

THE WHITE WIRE MUST BE CONNECTED TO NEUTRAL IN THE SERVICE BOX ENTRANCE AND THE MECHANICAL GROUND MUST BE CONNECTED TO A GROUNDING LUG IN THE SERVICE BOX OR THE MOTOR GENERATOR COMPARTMENT.

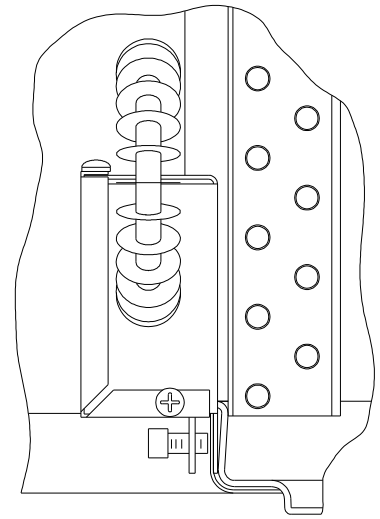

FIGURE 3

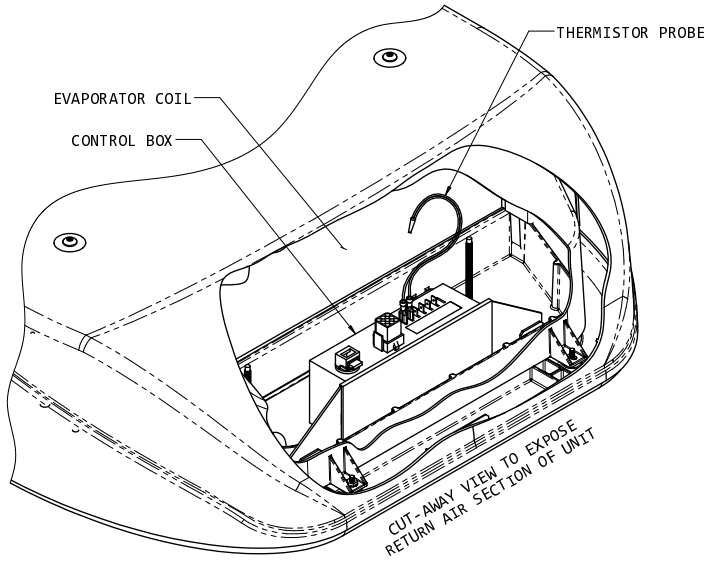

FIGURE 4

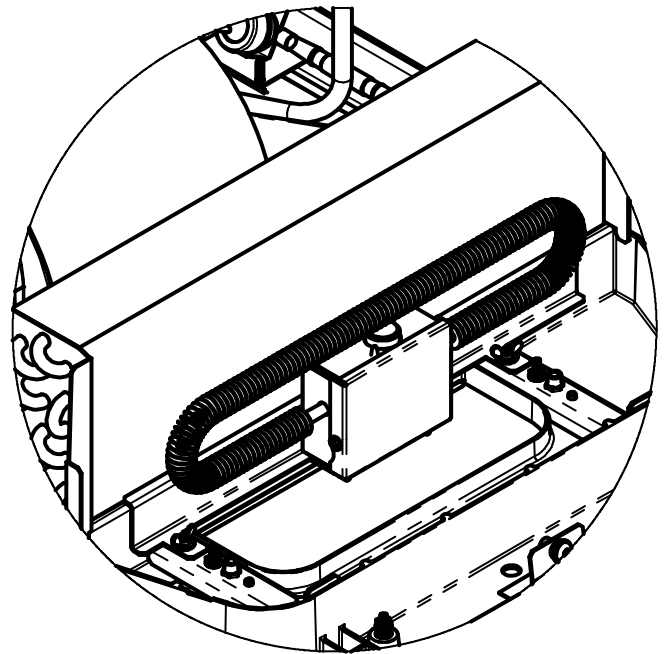

FIGURE 5