



**INSTALLATION INSTRUCTIONS**

**FOR**

**6531G692 PACKAGE AIR CONDITIONER**

**WITH**

**6531B625 ACCESSORY KIT**

# TABLE OF CONTENTS

<b>1.</b>	<b>Warnings</b> .....	<b>3</b>
<b>2.</b>	<b>Component Match-Up</b> .....	<b>3</b>
<b>3.</b>	<b>Specifications and Unit Identification</b> .....	<b>3</b>
<b>4.</b>	<b>Unit Depiction Figures</b> .....	<b>5</b>
<b>5.</b>	<b>General Information</b> .....	<b>6</b>
<b>6.</b>	<b>Unit Installation</b> .....	<b>6</b>
<b>7.</b>	<b>115 VAC Electrical Wiring</b> .....	<b>7</b>
<b>8.</b>	<b>Checkout</b> .....	<b>8</b>

# 1. WARNINGS

## IMPORTANT NOTICE

These instructions are for the use of qualified individuals specially trained and experienced in installation of this type equipment and related system components.

Installation and service personnel are required by some states to be licensed. **PERSONS NOT QUALIFIED SHALL NOT INSTALL NOR SERVICE THIS EQUIPMENT.**

## NOTE

The words "Shall" or "Must" indicate a requirement which is essential to satisfactory and safe product performance.

The words "Should" or "May" indicate a recommendation or advice which is not essential and not required but which may be useful or helpful.

## WARNING - SHOCK HAZARD

**To prevent the possibility of severe personal injury or equipment damage due to electrical shock, always be sure the electrical power source to the appliance is disconnected during installation.**

**CAREFULLY FOLLOW ALL INSTRUCTIONS AND WARNINGS IN THIS BOOKLET TO AVOID DAMAGE TO THE EQUIPMENT, PERSONAL INJURY OR FIRE.**

## WARNING

**Improper installation may damage equipment, can create a hazard and will void the warranty.**

**The use of components not tested in combination with this unit will void the warranty, may make the equipment in violation of state codes, may create a hazard and may ruin the equipment.**

# 2. COMPONENT MATCH-UP

- 6531G692 Package Air Conditioner
- 6531B625 Accessory Kit

# 3. SPECIFICATIONS AND UNIT IDENTIFICATION

## PACKAGE AIR CONDITIONER MODEL NUMBER BREAKDOWN

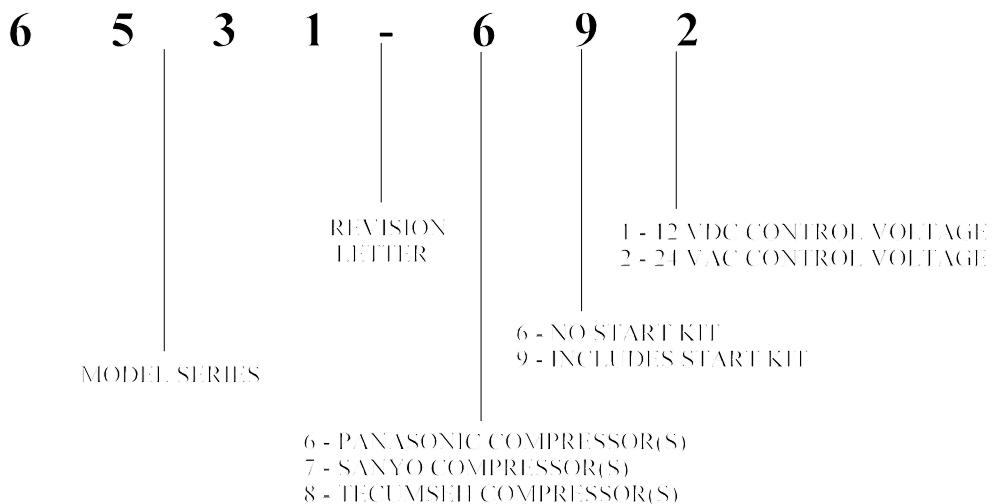

## SPECIFICATIONS

USE THERMOSTAT MODEL 7330B344  
 SUPPLIED WITH ACCESSORY  
 KIT #6531B625

<b>115</b>	<b>60</b>	<b>1</b>
<b>VOLTS AC</b>	<b>HZ</b>	<b>PHASE</b>
COMPRESSOR MOTOR (THERMALLY PROTECTED)		RLA <span style="border: 1px solid black; padding: 2px;">6.9</span>
		LRA <span style="border: 1px solid black; padding: 2px;">34.0</span>
ELECTRIC HEATER		FLA <span style="border: 1px solid black; padding: 2px;">12.5</span>
BLOWER/FAN MOTOR	1/3 H.P.	FLA <span style="border: 1px solid black; padding: 2px;">2.9</span>
MINIMUM CIRCUIT CAPACITY		AMP <span style="border: 1px solid black; padding: 2px;">20</span>
MAXIMUM OVERCURRENT PROTECTIVE DEVICE		AMP <span style="border: 1px solid black; padding: 2px;">20</span>
R-22 CHARGE WEIGHT		OZ. <span style="border: 1px solid black; padding: 2px;">14.75</span>
MINIMUM SUPPLY CONDUCTOR GAUGE (COPPER) UTILISER DES FILS D'ALIMENTATION EN CUIVRE		<span style="border: 1px solid black; padding: 2px;">#12</span>
UNIT 6531G692	WEIGHT LENGTH DEPTH HEIGHT	75 LBS. 22 1/8 18 1/8 19 3/4
ACCESSORY KIT 6531B625	WEIGHT LENGTH DEPTH HEIGHT	28 LBS. 15 7/8 16 9/32 10

## 4. UNIT DEPICTION FIGURES

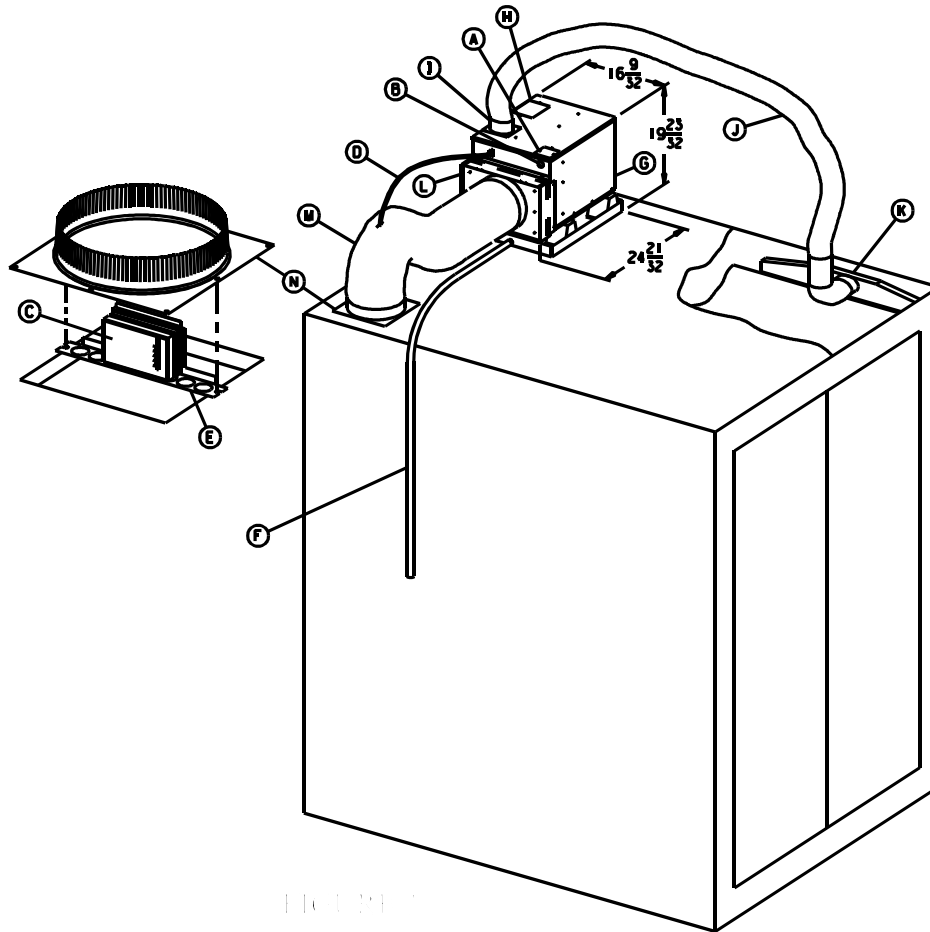

FIGURE 1

- |                                 |  |
|---------------------------------|--|
| (A) FIELD WIRING ACCESS DOOR    | (M) CONDENSER AIR DISCHARGE                |
| (B) POWER WIRE ENTRY            | (I) SUPPLY DUCT ADAPTOR ASSEMBLY           |
| (C) THERMOSTAT                  | (J) 4" DIA. INSULATED SUPPLY AIR FLEX DUCT |
| (D) THERMOSTAT EXTENSION CABLE  | (K) AIR DISTRIBUTION SCOOP                 |
| (E) THERMOSTAT MOUNTING BRACKET | (L) RETURN AIR BONNET & FILTER             |
| (F) CONDENSATE DRAIN HOSE       | (N) 10" DIA. RETURN AIR FLEX DUCT          |
| (G) CONDENSER AIR INLET         | (O) RETURN DUCT ADAPTOR ASSEMBLY           |

## 5. GENERAL INFORMATION

The 6531 series package air conditioners are intended for installation on the roof of elevator cabs or like-sized indoor use contrivances. It is understood that the manufacturer has provided an installation area which allows for cutouts and unit mounting without cutting vital frame members or electrical wiring and that structural members do not create restrictions by passing through airways required by the air conditioner. A recommended installation is shown in Figure 1.

Conditioned air is delivered from the air conditioner to the interior of the enclosure through ducting that is supplied in Accessory Kit #6531B625.

The system return air duct, return air filter and thermostat are also found in the Accessory Kit.

The air conditioner is powered by a 115 volt, 60 Hz, 1 Phase, 20 Amp electrical service.

## 6. UNIT INSTALLATION

1. The air conditioner draws in topside air to cool the condensing coil. The condenser air is drawn in from the end of the air conditioner (across the condensing coil), and discharged out through the top of the appliance (through the discharge opening). To provide adequate condensing air flow, the installer must adhere to the following guidelines:
  - a) The topside air path to the condensing coil should be as direct and non-restrictive as possible.
  - b) Any decorative grille or louver used as an opening for condenser air flow should have a minimum of 90 square inches of free area.
  - c) Do not block or restrict the discharge air opening.
  - d) Insure that there are no structural members or panels which would serve to cause condenser discharge air recirculation into the condenser return air.
2. Mount the air conditioning unit. The four shipping brackets may be used to secure the unit to the mounting surface, or the installer may choose to use bands or other types of bracketing.
3. Attach the supply duct adaptor to the top of the unit with the four existing screws in the unit top.
4. Mount the thermostat to the thermostat bracket using the screws provided with the thermostat.
5. Cut a 10 1/8" square opening in the canopy. The opening should be as remote as possible from the intended position of the supply air distribution scoop and away from any heat source such as lighting.
6. Fasten the thermostat/bracket and the return air duct adaptor over the square opening with screws or rivets. Use a quality duct tape to seal around the perimeter of the adaptor plate.
7. Install the supply air distribution scoop inside the conditioned space in an area as remote from the return air as possible. Air from the scoop should have a clear path into the conditioned area. Attach the scoop with adhesive, straps, brackets or by fastening through the part. If attaching with fasteners, pre-drill any clearance holes in the scoop to prevent cracking during installation. It is good practice to mount the scoop as far as possible from heat producing devices, such as lights, fixtures, etc.
8. Cut a 6" dia. hole in the roof to allow passage of the insulated 4" flex duct. The duct connects between the 4" collar at the unit and the oval opening at the air scoop. Secure the duct with 2 of the 4 cable ties provided in the accessory kit.
9. Secure the 7/8" I.D. condensate drain hose to the unit drain pan with the hose clamp provided in the kit.
10. Mount the return air bonnet to the unit using existing unit screws. Clearance holes on the return air bonnet align with existing unit fasteners. Use a good quality duct tape to seal the bottom and side seams between the unit and return air bonnet.
11. Install the return air filter inside the bonnet assembly with the wire mesh of the filter facing the unit evaporator coil.
12. Attach the unit end of the return air flex duct to the return air bonnet with one cable tie provided in the kit.

13. Cut a small slit through the return air flex duct directly above the adaptor plate to provide clearance for the thermostat cable to enter the return air opening.
14. Route the thermostat extension cable through the flex duct and plug one end into the thermostat, the other end into the unit.
15. Attach the return air flex duct to the adaptor plate and secure with one cable tie provided in the kit.
16. Use a quality duct tape to seal the opening in the return air flex duct around the thermostat cable.

**DANGER - SHOCK HAZARD**

**Do not drill any openings into this air conditioner. When attaching ducting directly to the air conditioner, use only the pilot holes already provided. Drilling new openings and inserting screws may damage either the refrigeration circuit or electrical wiring causing possible equipment damage, personal injury or death.**

## **7. 115 VAC ELECTRICAL WIRING**

**1. WARNING - SHOCK HAZARD**

**To prevent the possibility of severe personal injury or equipment damage due to electrical shock, always be sure the electrical power is disconnected or off before beginning installation.**

2. This air conditioner contains a compressor refrigeration system and requires power from a 115 volt electrical circuit. The circuit connects to a terminal block inside the main unit.
3. High Voltage Routing Specifications

When routing the high voltage supply wiring, both the following guidelines must be followed:

- A) High voltage wiring must be routed through a separate opening in the outer cabinet. This opening is referred to as the "power wire entry" (See Figure 1). RV Products provides a 7/8" diameter opening for 1/2" conduit. A knockout for 3/4" conduit is also provided.
- B) Do not allow excess wiring to contact electrical terminals, sharp screw ends or edging that can cut or damage the wiring insulation.
- C) After connecting the ground wire to the grounding lug, verify that the ground wire (which in some instances will be bare copper) cannot come into contact with any high voltage terminal.

**DANGER**

**WHEN USING NON-METALLIC SHEATH SUPPLY CABLES (ROMEX, ETC.), STRIP SHEATH BACK TO EXPOSE 4-6 INCHES OF THE SUPPLY LEADS. STRIP THE INDIVIDUAL WIRE LEAD ENDS FOR WIRE CONNECTION (ABOUT 3/4" BARE WIRE). INSERT THE SUPPLY WIRES INTO THE ELECTRICAL CONNECTOR CLAMP. SHEATH MUST PROTRUDE PAST CLAMP BUSHING INSIDE THE BOX. MAKE SURE SHEATH CABLE IS CENTERED IN CLAMP BEFORE TIGHTENING IT. DO NOT OVERTIGHTEN!! THIS COULD RESULT IN PINCHING THROUGH THE PLASTIC WIRE INSULATION AND CAUSE SHORTING OR "HOT" WIRES TO GROUND (SHOCK HAZARD). THE CLAMP IS INTENDED FOR STRAIN RELIEF OF THE WIRES. SLIGHT PRESSURE IS USUALLY SUFFICIENT TO ACCOMPLISH THIS.**

**IF OTHER THAN NON-METALLIC CABLES ARE USED FOR SUPPLY CONDUCTORS, APPROPRIATE STRAIN RELIEF CONNECTORS OR CLAMPS SHOULD BE USED.**

**IN NO CASE SHOULD CLAMPING OR PINCHING ACTION BE APPLIED TO THE INDIVIDUAL SUPPLY LEADS (NEUTRAL AND "HOT" WIRES).**

**DANGER - SHOCK HAZARD**

**TO PREVENT THE POSSIBILITY OF SHOCK INJURY FROM APPLIANCE OPERATION:**

**THE WHITE WIRE MUST BE CONNECTED TO NEUTRAL IN THE SERVICE BOX ENTRANCE AND THE MECHANICAL GROUND MUST BE CONNECTED TO A GROUNDING LUG EITHER IN THE SERVICE BOX OR THE MOTOR GENERATOR COMPARTMENT.**

In order to utilize smaller gauge, less expensive follower cables, it may be economical to provide a stepdown transformer at the elevator car to provide power for the air conditioner.

**8. CHECKOUT**

1. Before engaging power to any system, insure the following:
  - A) all tools have been removed from the equipment;
  - B) all wiring is attached, routed and properly secured;
  - C) all panels (both mechanical and electrical) are in place;
  - D) the thermostat system switch is placed into the "OFF" position and;
  - E) all co-workers have been warned that the equipment is being energized.
2. System wiring may be checked by referring to the wiring diagram located on the side of the unit.
3. Before beginning the checkout procedure, thoroughly read the checkout instructions.
4. After complying with steps 1 through 3, engage power to all systems and begin checkout procedure.

**THERMOSTAT OPERATIONS**

<input checked="" type="checkbox"/> SHOWS POSITION OF SWITCH					7330B344 OPERATION
SYSTEM HEAT OFF COOL			FAN AUTO FAN		
<input type="checkbox"/>	<input checked="" type="checkbox"/>	<input type="checkbox"/>	<input checked="" type="checkbox"/>	<input type="checkbox"/>	Operation of all components is stopped.
<input type="checkbox"/>	<input checked="" type="checkbox"/>	<input type="checkbox"/>	<input type="checkbox"/>	<input checked="" type="checkbox"/>	Cooling fan runs continuously. No compressor operation.
<input type="checkbox"/>	<input type="checkbox"/>	<input checked="" type="checkbox"/>	<input checked="" type="checkbox"/>	<input type="checkbox"/>	Cooling blower and compressor cycle with thermostat.
<input type="checkbox"/>	<input type="checkbox"/>	<input checked="" type="checkbox"/>	<input type="checkbox"/>	<input checked="" type="checkbox"/>	Cooling blower operates continuously. Compressor cycles with thermostat.
<input checked="" type="checkbox"/>	<input type="checkbox"/>	<input type="checkbox"/>	<input checked="" type="checkbox"/>	<input type="checkbox"/>	Heating system and blower cycle from thermostat.
<input checked="" type="checkbox"/>	<input type="checkbox"/>	<input type="checkbox"/>	<input type="checkbox"/>	<input checked="" type="checkbox"/>	Heating system cycles from thermostat. Cooling blower operates continuously.

**ADJUSTING SETPOINT:** To adjust the temperature control setpoint, move the temperature select lever located on the side of the thermostat to the temperature desired.





**RV Products**  
**A Division of Airxcel, Inc.**  
**P.O. Box 4020**  
**Wichita, KS 67204**