



INSTALLATION INSTRUCTIONS

FOR

ALL 6700 SERIES ROOF TOP

AIR CONDITIONERS

TABLE OF CONTENTS

Section I	General Information	2
Section II	Air Conditioning Sizing	3
Section III	Selecting An Installation Location	3
Section IV	Installing The Roof Top Unit	4
Section V	Installing The Ceiling Assembly	6
Section VI	Electrical Wiring	8
Section VII	Completing The Installation	10

These instructions are a general guide for installing all 6700 series roof top air conditioners. For specific air conditioner details, it will be necessary to refer to the printed product data information for the series air conditioner being installed (Customer Envelope Package).

IMPORTANT NOTICE

These instructions are for the use of qualified individuals specifically trained and experienced in installation of this type equipment and related system components.

Installation and service personnel are required in some states to be licensed. PERSONS NOT QUALIFIED SHALL NOT INSTALL NOR SERVICE THIS EQUIPMENT.

NOTE

The words "Shall" or "Must" indicate a requirement which is essential to satisfactory and safe product performance.

The words "Should" or "May" indicate a recommendation or advice which is not essential and not required but may be useful or helpful.

WARNING — SHOCK HAZARD

To prevent the possibility of severe personal injury or equipment damage due to electrical shock, always be sure the electrical source to the appliance is disconnected.

CAREFULLY FOLLOW ALL INSTRUCTIONS AND WARNINGS IN THIS BOOKLET TO AVOID DAMAGE TO THE EQUIPMENT, PERSONAL INJURY OR FIRE.

WARNING

Improper installation may damage equipment, can create a hazard and will void the warranty.

The use of components not tested in combination with these units will void the warranty, may make the equipment in violation of state codes, may create a hazard and may ruin the equipment.

SECTION I — GENERAL INFORMATION

OEM - Please make sure that the Customer Envelope Package accompanies the air conditioner.

INSTALLER AND/OR DEALER - Please make sure the Customer Envelope Package is presented to the product consumer. The product consumer should also be afforded the opportunity to purchase the optional four (4) year compressor replacement contract available from Recreation Vehicle Products, Inc. (excluding "Roughneck" and "Packaged" air conditioners).

For more information about the contract, please review the application and contract sample located in the Operation and Maintenance Instructions Booklet (Customer Envelope Package).

If installing a 6799-*1* unit with internal condensate drain, read Section V, Item G. This step is applicable to all ceiling assemblies.

INQUIRIES ABOUT THE A/C UNIT - Inquiries to your R.V. Products representative or to R.V. Products, Inc. pertaining to product installation should contain both the model and serial numbers of the roof top a/c unit. All roof top a/c units have model and serial number identification in two locations:

1. On the rating plate sticker, which may be viewed by looking through the shroud louvers of the compressor side. The rating plate sticker can be seen without removing the outer plastic shroud.
2. On the model/serial number sticker (silver color) Located on the bottom of the basepan. If the a/c unit is already installed, the sticker may be viewed by lowering the ceiling assembly shroud.

SECTION II — AIR CONDITIONER SIZING

The ability of an air conditioner to provide a comfortable environment for the customer is dependent upon the following conditions.

Air conditioners are rated primarily by their ability to remove heat. The thermal measurement used for detecting a gain or loss of heat is the British Thermal Unit (BTU). One (1) BTU is the amount of heat required to raise the temperature of one (1) pound of water one (1) degree Fahrenheit. An air conditioner rated at 13,500 BTUH can only remove 13,500 BTU's of heat in one (1) hour.

The ability of an air conditioner to cool down a vehicle or maintain a consumer desired temperature is dependent upon the heat gain of the vehicle. The physical size, the amount of window area, the quality and amount of insulation, the amount of vehicle surface exposed to sunlight due to its position, the number of people using the vehicle, may increase the heat gain to such an extent that the capacity of the air conditioner is exceeded.

The size of recreational vehicle air conditioners are generally limited to 13,500 BTUH (approximately one ton) of cooling. This is due to the limited electrical supply found in most RV parks and/or limitations of generators with enough capacity to

handle larger air conditioners. If more than 13,500 BTU's of cooling capacity is desired, then the use of two air conditioners is recommended.

As a general rule, air supplied (discharge air) from the air conditioner will be 15 to 20 degrees cooler than the air entering (return air) the ceiling assemblies bottom air grills. For example, if the air entering the air conditioner is 80 degrees F (return air), the supply air (discharge air) into the vehicle will be 60 to 65 degrees F. As long as this temperature difference (15 to 20 degrees) is being maintained at the air conditioner, the air conditioner is operating properly.

Again, give careful consideration to the vehicle heat gain variables. During extreme outdoor temperatures, the heat gain of the vehicle may be reduced by:

- C parking the vehicle in a shaded area
- C keeping windows and doors closed
- C avoiding the use of heat producing appliances
- C using window shades (blinds and/or curtains)

For a more permanent solution to high heat gain situations, additional vehicle insulation and/or window glass tinting should be considered.

SECTION III — SELECTING AN INSTALLATION LOCATION

Your R.V. Products air conditioner has been designed for use primarily in recreational vehicles.

Is the roof of the vehicle capable of supporting both the roof top unit and ceiling assembly without additional support structures? Inspect the interior ceiling mounting area to avoid interference with existing structural members such as; bunks, curtains, tracks or room dividers (See Product Data Sheet for ceiling shroud dimensions). The depth of the ceiling assembly shroud is 3". Be sure to check clearance for doors which must be swung open (refrigerator, closets, cabinets).

Most of the time, roof mount air conditioners are installed at existing roof vent locations. If there are no roof vents (existing mounting hole), the following placement locations are recommended.

Motor Homes - a single unit or the forward of two units should be mounted within 9 feet of the drivers compartment.

Travel Trailers or Mini-Homes - a location should be selected that is near the door slightly forward of the vehicle center length.

Vans - location should be in the center of the roof (side to side - front to back).

Truck with Camper - location should be between 4 and 5 feet from the rear of the camper to achieve maximum cooling effect.

SECTION IV — INSTALLING THE ROOF TOP UNIT

DANGER SHOCK HAZARD

DISCONNECT ALL POWER TO THE VEHICLE BEFORE PERFORMING ANY CUTTING TO THE VEHICLE. CONTACT WITH HIGH VOLTAGE CAN RESULT IN EQUIPMENT DAMAGE, PERSONAL INJURY OR DEATH.

IMPORTANT

TO PREVENT DAMAGE TO THE WIRING AND BATTERY, DISCONNECT THE BATTERY CABLE FROM THE POSITIVE BATTERY TERMINAL BEFORE PERFORMING ANY CUTTING TO THE VEHICLE.

Once the location for your air conditioner has been determined (See Section III), a reinforced and framed 14" x 14" roof hole opening must be provided (may use existing vent hole). Before cutting into the vehicle roof, verify that the cutting action will clear all structural members and crossbeams. Additionally, the location of any inner roof plumbing and electrical supplies must be considered.

- A. If a roof vent is already present in the desired mounting location for the air conditioner, the following steps must be taken:
 - 1. Remove all screws which secure the roof vent to the vehicle. Remove the vent and any additional trim materials. Carefully remove all caulking from around the roof vent opening to obtain clean exterior roof surface.

- 2. It may be necessary to seal some of the old roof vent mounting screw holes which may fall outside of the air conditioner basepan gasket.
- 3. Examine the roof opening. If the opening is smaller than 14" x 14", the opening must be enlarged. If the opening exceeds 14 1/2" x 14 1/2", a mounting plate (frame) must be field fabricated to reduce the opening size.

- B. If a roof vent opening is not used, a new 14" x 14" opening will have to be cut into the vehicle roof. A matching opening will also have to be cut into the interior vehicle ceiling. Be careful when cutting the ceiling opening. If the interior ceiling is carpeted, snagging could occur. After the opening in the roof and interior ceiling are the correct size, a framed support structure must be provided between the exterior roof top and interior ceiling. The reinforced framed structure must provide the following qualities:

- 1. Capable of supporting both the weight of the roof top air conditioner and the interior ceiling assembly.
- 2. Capable of holding or supporting the roof outer surface and interior ceiling apart, so that when the roof top air conditioner and ceiling assembly are bolted together, no collapsing occurs.

RV Products recommends that the spacing from the vehicle roof top to the interior ceiling top be no less than 3/4". A typical support frame is shown in Figure 1.

The frame must provide an opening through the frame to allow passage for the 115 VAC power supply wiring. Route the 115 VAC supply wiring through the frame at the same time the support frame is being installed. For proper wiring size, refer to the supply wiring chart (Figure 2).

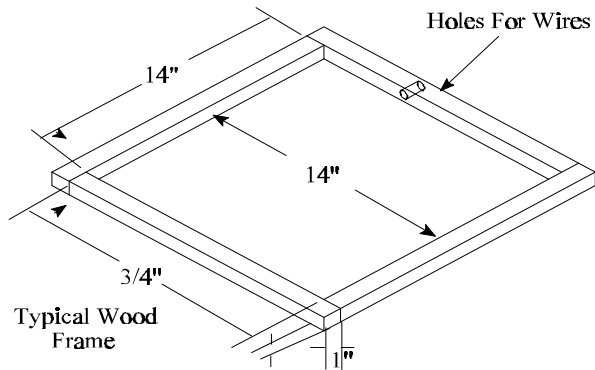

FIGURE 1

SUPPLY WIRING SIZING	
CIRCUIT PROTECTION	MINIMUM WIRING SIZE*
Max. Time Delay Fuse: 20 AMP Max. Circuit Breaker U.L. (H.A.C.R. Type) 20 AMP C.S.A. 20 AMP	Copper Conductors Only (0' - 25') #12 AWG (26' - 75') #10 AWG (76' - 100') #8 AWG
* It is necessary to include wiring length in vehicle wall when figuring gauge of wire to use. Wiring in vehicle wall need not be replaced if #12 AWG or larger.	

FIGURE 2

IMPORTANT - Allow 24" of supply wiring through the support frame (working length).

After the support frame is installed, seal off all gaps between the frame and both the roof exterior and the interior ceiling of the vehicle (cavity walls). Additionally, seal the gap around the electrical supply wiring.

C. This air conditioner is to be installed in accordance with the NFPA Standard 501C.

D. The roof top air conditioner must be mounted as near level from front to rear and side to side as is possible when the vehicle is parked on a level plane. Figures 3 and 4 show maximum allowable degree deviations (mounting degrees from total surface flat plane).

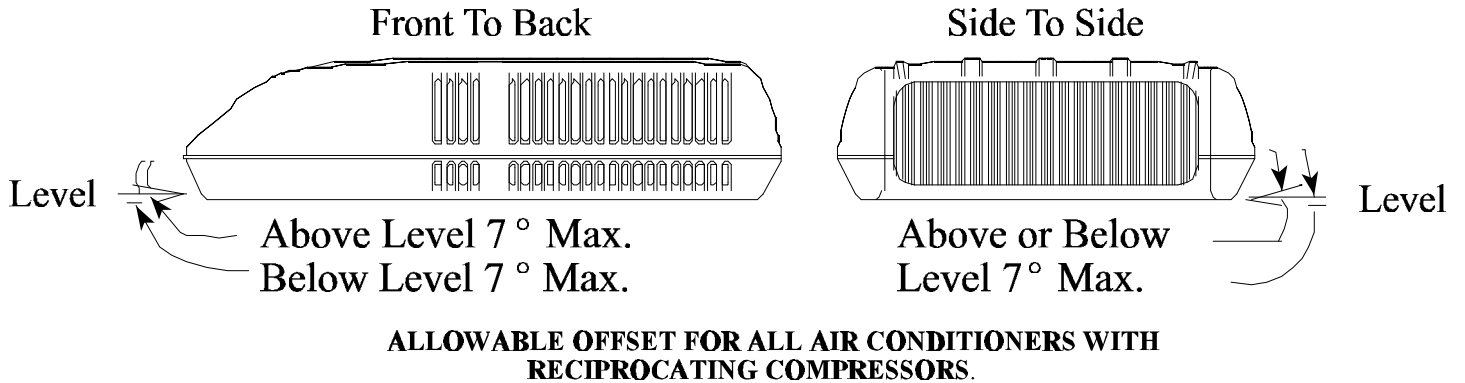

FIGURE 3

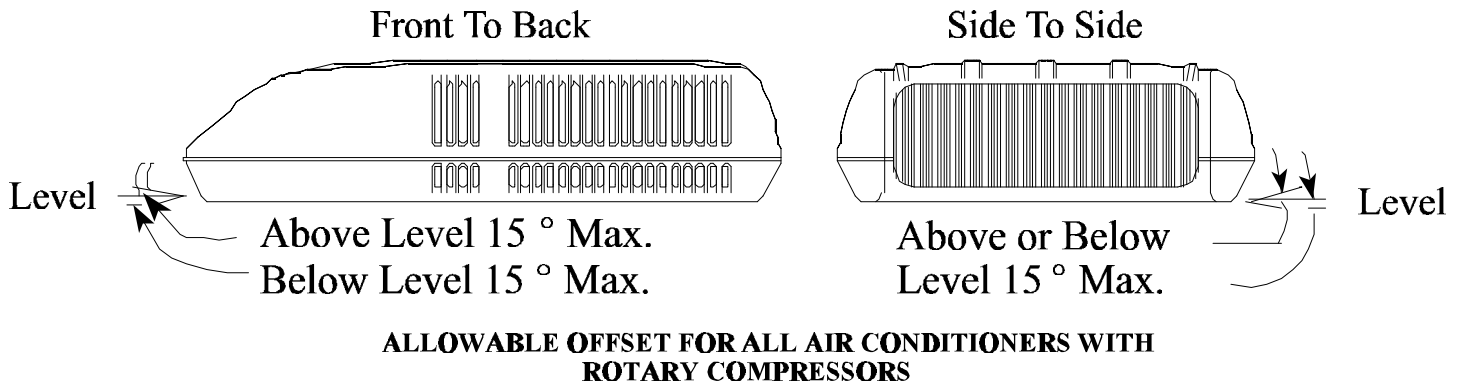

FIGURE 4

If the roof of the vehicle is sloped (not level) such that the roof top air conditioner cannot be mounted within the maximum allowable degree deviations, an exterior leveling shim will need to be added to make the roof top air conditioner level. A typical leveling shim is shown in Figure 5.

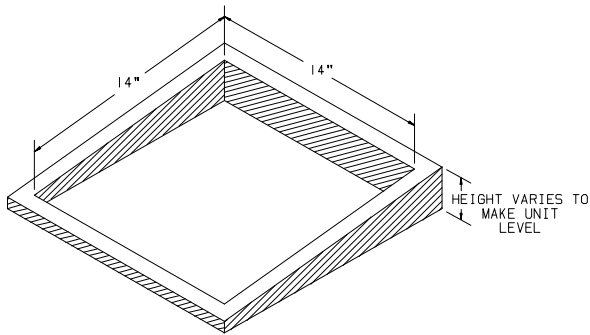

FIGURE 5

SECTION V — INSTALLING THE CEILING ASSEMBLY

NOTE

The optional Elect-A-Heat is intended to take the chill out of the indoor air when the air is a few degrees too cool for comfort. The Elect-A-Heat is an effective “chill chaser”. **It is not a substitute for a furnace.**

Make sure that you have properly matched the roof top air conditioner and interior ceiling assembly. All “D” model production roof top air conditioners and ceiling assemblies will have a four (4) bolt mounting pattern (example 6759D707 A/C, 6759D716 C/A). The following step by step instructions must be performed in the following sequence to insure proper installation.

- A. Carefully uncarton the ceiling assembly. Controls are factory installed in the ceiling assembly (except ceiling assemblies for applications with remote control box/thermostat).
- B. Remove the two screws that secure the ceiling assembly shroud to the metal ceiling assembly plate.
- C. Remove the shroud from the ceiling assembly plate.
- D. On ceiling assemblies equipped with the Elect-A-Heat heater package (heat/cool ceiling assemblies), detach the bottom heating element support plate by loosening the six (6) screws located around the outer edge. The heat element support plate can now be slid over the screw heads. The electrical connection plug will need to be disconnected before the heat element support plate can be removed. **THIS ENTIRE STEP ‘D’ IS NOT REQUIRED ON COOLING ONLY CEILING ASSEMBLIES.**
- E. Before the ceiling assembly can be mounted to the roof top air conditioner, the soft aluminum duct collar must be properly sized (trimmed). Measure the distance between the bottom of the air conditioner basepan and the vehicle interior ceiling line (See Figure 6). Take the aluminum duct collar and trim its height to this measurement less 1/2".
- F. Square the duct collar (hand form) and place the untrimmed (factory sheared) end of the duct collar over the ceiling assembly discharge opening flange (See Figure 6).
- G. Before lifting (mounting) the ceiling plate, check the gasket on the underside of the roof top air conditioner. The gasket must be centered over the 14" x 14" roof opening.

Once the roof top air conditioner has been leveled, some additional shimming may be required above the interior ceiling assembly. The roof top air conditioner and the interior ceiling assembly must have a squared installation relationship before they are secured together.

- E. After the mounting hole area is properly prepared, remove the carton and shipping pads from around the roof top air conditioner. **Carefully** lift the unit on top of the vehicle. Do not use the outer plastic shroud for lifting. Place the roof top air conditioner over the prepared 14" x 14" mounting hole. The pointed end (nose) of the shroud must face towards the front of the vehicle. From inside the vehicle, remove the plastic tie which secures the electrical conduit to the bottom of the air conditioner unit. Pull the electrical conduit down from the roof air conditioner through the mounting opening and let hang.

Also, at this time, if installing a 6799-*1* unit with internal condensate drain, attach a 1/2" I.D. drain hose with clamp to one of the two barbed fittings. Barb fitting used will determine routing of hose. Insure that the supplied plastic cover is installed over the unused barb fitting.

- H. Before lifting (mounting) the ceiling plate, place the washers (C/A small parts package) on the mounting bolts.
- I. Raise the ceiling plate and duct collar up to the roof top air conditioner bottom basepan making sure the duct collar is aligned and properly fits around the blower discharge opening of the roof top air

conditioner. Secure the ceiling assembly plate to the roof top air conditioner with the mounting bolts/washers. The mounting bolts/washers must be started (threaded) by hand to avoid cross-threading. **DO NOT START THE MOUNTING BOLTS/WASHERS WITH AN AIR GUN.** Mounting bolts should be tightened evenly. A rotation tightening procedure (similar to car tire rim mounting) is essential for proper gasket compression. Do not initially overtighten each bolt. RV Products recommends at least two complete rotation tightening passes. The bolt tightening process is complete when the roof top air conditioner basepan has been evenly compressed 50%. Figure 7 shows a typical four (4) bolt installation.

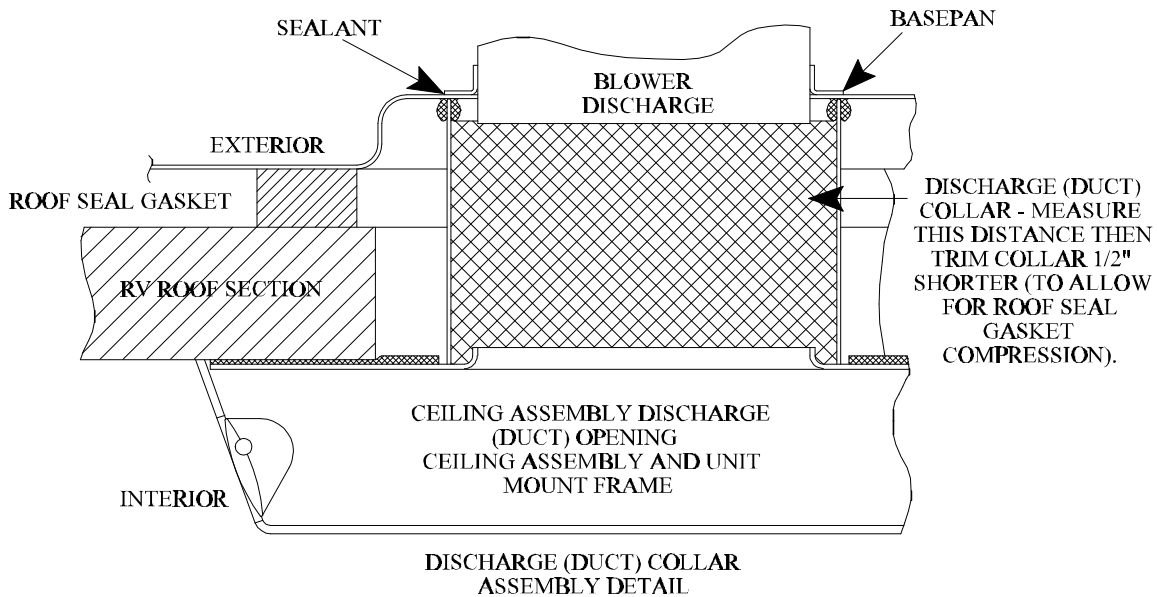

FIGURE 6

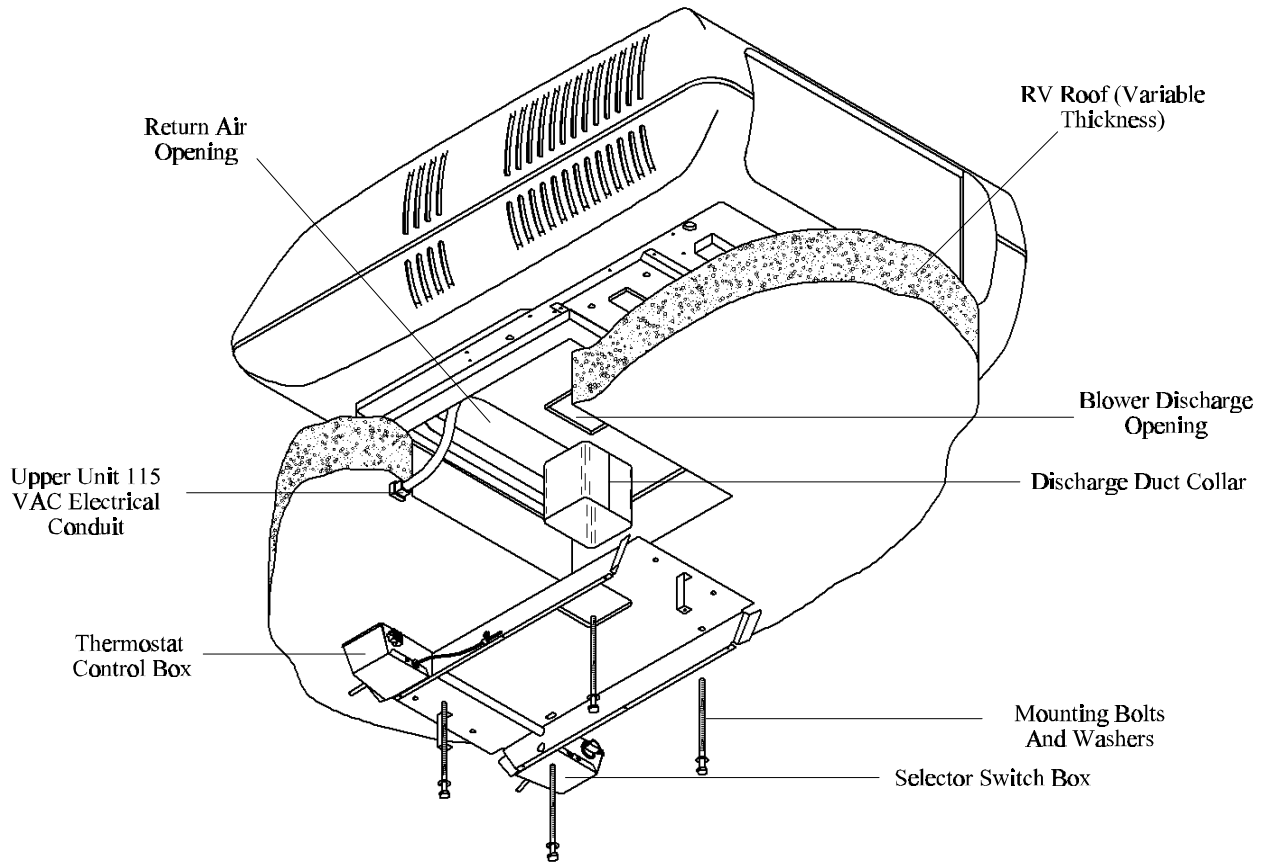

FIGURE 7

SECTION VI — ELECTRICAL WIRING

IMPORTANT

U.L. APPROVAL REQUIRES THE POWER SUPPLY TO BE “COPPER CONDUCTORS ONLY”.

DANGER — SHOCK HAZARD

MAKE SURE THAT ALL POWER SUPPLY TO THE UNIT IS DISCONNECTED BEFORE PERFORMING ANY WORK ON THE UNIT TO AVOID THE POSSIBILITY OF SHOCK INJURY OR DAMAGE TO THE EQUIPMENT.

After the interior ceiling plate is properly secured to the roof top air conditioner, the following electrical connections must be performed.

- A. Route the 115 volt power supply wire to the back of the selector switch control box. Do not attach at this time.

- B. Take the roof top air conditioner 115 VAC electrical conduit and plug it into the back of the thermostat control box. Make sure that the “ridged” side of the plug is aligned and matched with the “ridged” side of the thermostat control box connection. **DO NOT USE EXCESSIVE FORCE** and make sure the lock-in tabs are snapped in place. See Figure 8.
- C. Remove the selector switch control box cover (one screw). Take the 115 VAC supply wire and slide it into the back of the selector switch control box through the strain relief that is provided.

DANGER

WHEN USING NON-METALLIC SHEATH SUPPLY CABLES (ROMEX, ETC.), STRIP SHEATH BACK TO EXPOSE 4-6 INCHES OF THE SUPPLY LEADS. STRIP THE INDIVIDUAL WIRE LEAD ENDS FOR WIRE CONNECTION (ABOUT 3/4" BARE WIRE). INSERT THE SUPPLY WIRES

INTO THE ELECTRICAL CONNECTOR CLAMP. SHEATH MUST PROTRUDE PAST THE CLAMP BUSHING INSIDE OF BOX AS ILLUSTRATED. MAKE SURE SHEATH CABLE IS CENTERED IN CLAMP TIGHTENING UP ON IT. DO NOT OVERTIGHTEN!! THIS COULD RESULT IN PINCHING THROUGH THE PLASTIC WIRE INSULATION AND CAUSE SHORTING OR "HOT" WIRES TO GROUND (SHOCK HAZARD). THE CLAMP IS INTENDED FOR STRAIN RELIEF OF THE WIRES. SLIGHT PRESSURE IS USUALLY SUFFICIENT TO ACCOMPLISH THIS.

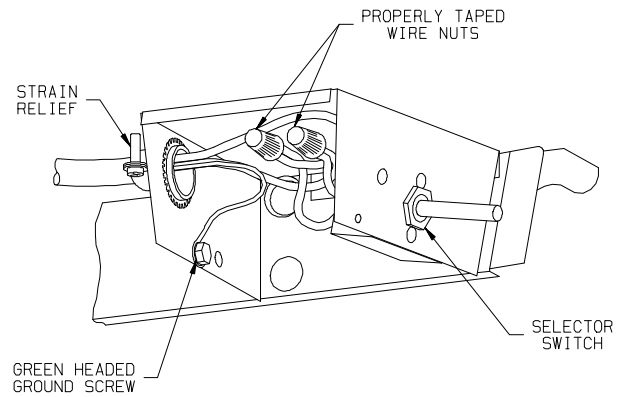

FIGURE 9

IF OTHER THAN NON-METALLIC CABLES ARE USED FOR SUPPLY CONDUCTORS, APPROPRIATE STRAIN RELIEF CONNECTORS OR CLAMPS SHOULD BE USED.

IN NO CASE SHOULD CLAMPING OR PINCHING ACTION BE APPLIED TO THE INDIVIDUAL SUPPLY LEADS (NEUTRAL AND "HOT" WIRES).

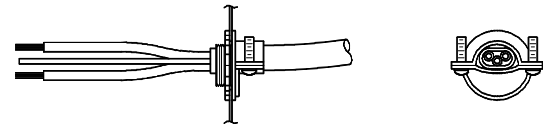

FIGURE 10

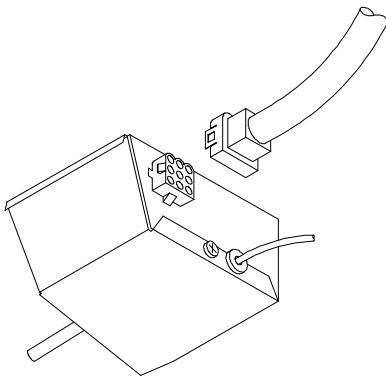

FIGURE 8

DANGER — SHOCK HAZARD

TO PREVENT THE POSSIBILITY OF SHOCK INJURY, THE WHITE WIRE MUST BE CONNECTED TO NEUTRAL IN THE SERVICE BOX ENTRANCE AND THE MECHANICAL GROUND MUST BE CONNECTED TO A GROUNDING LUG EITHER IN THE SERVICE BOX OR THE MOTOR GENERATOR COMPARTMENT.

- D. Connect the 115 VAC power line to the black and white pigtail wires found in the control box using two wire nuts. **IMPORTANT** - Connect black wire to black wire and white wire to white wire. Install the 115 volt ground wire (green or bare copper) to the green headed screw in the selector switch control box. Using a U.L. approved electricians tape, secure the wire nuts to the wires in a workmanlike manner (See Figure 9).
- E. Tighten the strain relief clamp to secure the 115 VAC supply wire. **DO NOT OVERTIGHTEN** (See Figure 10). Reinstall the selector switch control box cover.

SECTION VII — COMPLETING THE INSTALLATION

To complete the installation and system checkout requirements, the following steps must be performed.

- A. Check the thermostat probe position. Make sure the thermostat probe is routed through the holding guide and is not touching any metal surface.
- B. Reinstall the Elect-A-Heat assembly by first; connecting the heat plug from the selector switch control box to the heater receptacle in the Elect-A-Heat heater package, and secondly; secure the Elect-A-Heat package (slide heating element support plate over six (6) mounting screws and secure). THIS ENTIRE STEP 'B' IS NOT REQUIRED ON COOLING ONLY CEILING ASSEMBLIES.
- C. Make sure the non-allergenic natural fiber filters are properly positioned in the ceiling shroud.
- D. Reinstall the ceiling shroud (secure with two screws provided by RV Products). Put the control knobs (found in the single parts package) on the selector switch and thermostat controls.
- E. Turn selector switch to OFF position.
- F. Turn ON the 115 VAC power supply to the roof top air conditioner.
- G. System Checkout - RV Products manufactures a wide range of roof top air conditioners which incorporate different product operation features. To properly evaluate the performance of a newly installed air conditioner, it is necessary to review the specific unit operation characteristics (features) described in product operation and maintenance instructions (Customer Envelope Package).



RV Products
A Division of Airxcel, Inc.
P.O. Box 4020
Wichita, KS 67204

